



Indian Telecom Security Assurance Requirements (ITSAR)
भारतीय दूरसंचार सुरक्षा आश्वासन आवश्यकताएँ (भा.दू.सु.आ.आ.)

Network Slice Admission Control Function (NSACF) of 5G
Draft for comments

ITSAR Number: ITSAR1112523MM

ITSAR Name: NCCS/ITSAR/Core Equipment/5G Sub-systems/ Network Slice Admission Control Function (NSACF) of 5G

Date of Release: DD.MM.YYYY

Version: 1.0.0

Date of Enforcement:

© रा.सं.सु.के.,
२०२३

MTCTE के तहत जारी:

Issued under MTCTE by:

राष्ट्रीय संचार सुरक्षा केंद्र (रा.सं.सु.के.)

दूरसंचार विभाग, संचार मंत्रालय

भारत सरकार

सिटी दूरभाष केंद्र, एसआर नगर, बैंगलोर-५६००२७, भारत

National Centre for Communication Security (NCCS)

Department of Telecommunications

Ministry of Communications

Government of India

City Telephone Exchange, SR Nagar, Bangalore-560027, India

About NCCS

National Centre for Communication Security (NCCS), with headquarters at Bengaluru was set up in 2018 with the objective to establish and operationalize a framework of security testing and certification within the country. NCCS is mandated to prepare Telecom security requirements/standards called Indian Telecommunication Security Assurance Requirements (ITSAR) that addresses the country specific security needs in telecommunication landscape and notify the same.

Document History

Sr No	Title	ITSAR No.	Version	Date of Release	Remark
1.	Network Slice Admission Control Function (NSACF) of 5G	ITSAR1112523MM	1.0.0	DD.MM.YYYY	First release

Table of Contents

A) Outline	viii
B) Scope	viii
C) Conventions	ix
Chapter 1 - Overview	1
Chapter 2 - Common Security Requirements.....	9
Section 2.1: Access and Authorization	9
2.1.1 Authentication for Product Management and Maintenance interfaces	9
2.1.2 Management Traffic Protection	9
2.1.3 Role-based access control policy.....	9
2.1.4 User authentication - Local/Remote.....	10
2.1.5 Remote login restrictions for privileged users	10
2.1.6 Authorization Policy.....	11
2.1.7 Unambiguous identification of the user & group accounts.....	11
Section 2.2: Authentication Attribute Management.....	11
2.2.1 Authentication Policy.....	11
2.2.2 Authentication Support – External.....	12
2.2.3 Protection against brute force and dictionary attacks.....	12
2.2.4 Enforce Strong Password	13
2.2.5 Inactive Session timeout.....	13
2.2.6 Password Changes	14
2.2.7 Protected Authentication feedback.....	15
2.2.8 Removal of predefined or default authentication attributes.....	15
2.2.9 Logout function	16
2.2.10 Policy regarding consecutive failed login attempts.....	16
2.2.11 Suspend accounts on non-use.....	17
Section 2.3: Software Security	17
2.3.1 Secure Update.....	17
2.3.2 Secure Upgrade	17
2.3.3 Source code security assurance.....	18
2.3.4 Known Malware and backdoor Check.....	18
2.3.5 No unused software.....	19
2.3.6 Unnecessary Services Removal.....	19
2.3.7 Restricting System Boot Source.....	20
2.3.8 Secure Time Synchronization	20
2.3.9 Restricted reachability of services.....	21
2.3.10 Self Testing	21
Section 2.4: System Secure Execution Environment	21
2.4.1 No unused functions.....	21

2.4.2 No unsupported components	22
2.4.3 Avoidance of Unspecified mode of Access	22
Section 2.5: User Audit	22
2.5.1 Audit trail storage and protection	22
2.5.2 Audit Event Generation.....	23
2.5.3 Secure Log Export	27
2.5.4 Logging access to personal data	27
Section 2.6: Data Protection	27
2.6.1 Cryptographic Based Secure Communication.....	27
2.6.2 Cryptographic Module Security Assurance	28
2.6.3. Cryptographic Algorithms implementation Security Assurance	28
2.6.4. Protecting data and information – Confidential System Internal Data	29
2.6.5. Protecting data and information in storage	29
2.6.6 Protection against Copy of Data.....	30
2.6.7 Protection against Data Exfiltration - Overt Channel.....	30
2.6.8 Protection against Data Exfiltration - Covert Channel.....	30
2.6.9 System robustness against unexpected input.....	31
2.6.10 Security of backup data	31
2.6.11 Secure deletion of sensitive data	31
Section 2.7: Network Services	31
2.7.1 Traffic Filtering – Network Level Requirement	32
2.7.2 Traffic Separation.....	32
2.7.3 Traffic Protection – Anti-Spoofing.....	33
Section 2.8: Attack Prevention Mechanisms.....	33
2.8.1 Network level and Application-level DDoS	33
2.8.2 Excessive Overload Protection.....	34
2.8.3 Interface robustness requirements.....	34
Section 2.9: Vulnerability Testing Requirements	35
2.9.1 Fuzzing – Network and Application Level	35
2.9.2 Port Scanning.....	35
2.9.3 Vulnerability Scanning.....	35
Section 2.10: Operating System	36
2.10.1 Growing Content Handling.....	36
2.10.2 Handling of ICMP	36
2.10.3 Authenticated Privilege Escalation only.....	38
2.10.4 System account identification.....	38
2.10.5 OS Hardening - Minimized kernel network functions.....	38
2.10.6 No automatic launch of removable media	39
2.10.7 Protection from buffer overflows.....	39
2.10.8 External file system mount restrictions.....	39

2.10.9 File-system Authorization privileges.....	39
2.10.10 SYN Flood Prevention.....	40
2.10.11 Handling of IP options and extensions	40
2.10.12 Restrictions on running Scripts / Batch-processes	40
2.10.13 Restrictions on Soft-Restart.....	40
Section 2.11: Web Servers.....	41
2.11.1 HTTPS.....	41
2.11.2 Webserver logging	41
2.11.3 HTTPS input validation	41
2.11.4 No system privileges	42
2.11.5 No unused HTTPS methods	42
2.11.6 No unused add-ons	42
2.11.7 No compiler, interpreter, or shell via CGI or other server-side scripting.....	42
2.11.8 No CGI or other scripting for uploads.....	43
2.11.9 No execution of system commands with SSI.....	43
2.11.10 Access rights for web server configuration	43
2.11.11 No default content	43
2.11.12 No directory listings.....	43
2.11.13 Web server information in HTTPS headers.....	44
2.11.14 Web server information in error pages.....	44
2.11.15 Minimized file type mappings.....	44
2.11.16 Restricted file access.....	44
2.11.17 HTTP User sessions.....	45
Section 2.12: General SBA/SBI Aspects	45
2.12.1 No code execution or inclusion of external resources by JSON parsers.....	46
2.12.2 Validation of the unique key values in Information Elements (IEs).....	46
2.12.3 Validation of the IEs limits	46
2.12.4 Protection at the transport layer.....	46
2.12.5 Authorization token verification failure handling within one PLMN.....	47
2.12.6 Authorization token verification failure handling different PLMNs.....	48
2.12.7 Protection against JSON injection attacks	48
Section 2.13: Other Security requirements	48
2.13.1 Remote Diagnostic Procedure – Verification.....	48
2.13.2 No System Password Recovery	49
2.13.3 Secure System Software Revocation	49
2.13.4 Software Integrity Check – Installation.....	49
2.13.5 Software Integrity Check – Boot	49
2.13.6 Unused Physical and Logical Interfaces Disabling.....	50
2.13.7 Predefined accounts shall be deleted or disabled.....	50
2.13.8 Correct handling of client credentials assertion validation failure.....	50

2.13.9 Isolation of Compromised Element	51
Chapter 3 – Specific Security Requirements	52
Section 3.1 NSACF Database related Requirements	52
3.1.1 Removal of default accounts in database.....	52
3.1.2 Renaming Of root/admin account in the database	52
3.1.3 Removal of default database.....	52
3.1.4 Password management for the database.....	52
3.1.5 Protection of the NSACF database	53
3.1.6 Database specific logging	54
3.1.7 User privileges on the database.....	54
3.1.8 Unique Identity.....	54
3.1.9 Protection from attacks	54
3.1.10 NSACF Database Integrity	55
3.1.11 NSACF Database Availability.....	55
3.1.12 Support for ‘Data Redaction’ and ‘Data Masking’ feature	56
3.1.13 Terminate session on logout or session termination event.....	56
3.1.14 Fail in known secure state.....	56
3.1.15 Disable server-side scripting if not needed.....	56
3.1.16 Restrict access using IP filtering.....	57
3.1.17 Database backup.....	57
Section 3.2. Network slice Admission Control Service.....	57
3.2.1 NSACF supervision/reporting data protection.....	57
3.2.2 Protection against potential leakage of sensitive information.....	57
Annexure-I.....	59
Annexure-II	62
Annexure-III.....	66
Annexure- IV	67

A) Outline

The objective of this document is to present comprehensive, country-specific security requirements for the Network Slice Admission Control Function (NSACF) network function of 5G Core. As part of the Network Slice service architecture, NSACF supports monitoring and controlling i) number of registered UEs per network slice, ii) number of established PDU Sessions per network slice, iii) event-based Network Slice status notification and reports to a consumer NF.

The specifications produced by various regional/ international standardization bodies/organizations/associations like 3rd Generation Partnership Project (3GPP), International Telecommunication Union - Telecommunications Standardization Sector (ITU-T), International Organization for Standardization (ISO), European Telecommunications Standards Institute (ETSI), Internet Engineering Task Force (IETF), Internet Research Task Force (IRTF), Global System for Mobile communication Association (GSMA), Telecommunications Standards Development Society of India (TSDSI) et. al. along with the country-specific security requirements are the basis for this document. The Telecommunication Engineering Centre (TEC)/ TSDSI references made in this document implies that the respective clause has been adopted as it is or with certain modifications.

This document commences with a brief description of the 5G system architecture, NSACF and its functionalities and then proceeds to address the common and entity specific security requirements of NSACF.

B) Scope

This document targets on the security requirements of the 5G Core NSACF network function. This document does not cover the security requirements at the virtualization and infrastructure layers.

Remote Access regulations are governed by the Licensing Wing of the Department of Telecommunications (DoT).

C) Conventions

1. Must or shall or required denotes the absolute requirement of a particular clause of Indian Telecommunication Security Assurance Requirements (ITSAR).
2. Must not or shall not denote absolute prohibition of a particular clause of ITSAR.
3. Should or Recommended denotes that the particular clause of ITSAR may be ignored under justifiable circumstances but after careful examination of its implications.
4. Should not or not Recommended denotes the opposite meaning of (3) above.

Chapter 1 - Overview

1.1 Introduction

The fifth generation of mobile technologies (5G) is expected to connect people, things, data, applications, transport systems and cities in a smart networked communication environment. 5G is standardized by the 3GPP and the requirement framework for 5G are specified by ITU under International Mobile Telecommunications-2020 (IMT-2020). The usage scenarios/use cases identified for 5G are i) Enhanced Mobile Broadband (eMBB) ii) Massive Machine Type Communication (mMTC) and iii) Ultra Reliable and Low Latency Communications (URLLC).

1.2 5G Architecture

The 5G architecture supports various service deployments by using techniques like Software Defined Networking (SDN) and Network Function Virtualization (NFV). The generic 5G System (5GS) architecture consists of User Equipment (UE), Radio Access Network (RAN), supporting 3GPP (e.g., New Radio (NR) and Evolved Universal Terrestrial Radio Access (E-UTRA)), as well as non-3GPP access (e.g., Wireless Local Area Network (WLAN)) and 5G Core Network. The 5G NR base station is called Next Generation Node B (gNB). The deployment strategies possible are Non-Stand Alone (NSA) and Stand Alone (SA). SA denotes 5G NR RAN connecting to 5G Core Network. In NSA mode, 5G NR RAN (gNBs) gets connected to Fourth Generation (4G)'s Evolved Packet Core (EPC) but uses 4G Long Term Evolution (LTE) eNodeBs as anchor in the control plane.

1.2.1 5G Core Network

Core network is the central part of the mobile network. 5G Core network provides authentication, security, mobility management, session management services and allows the subscribers through access and authorization to avail the services. These functionalities of the 5G core network are supported using 3GPP defined processing functions specified as “network functions”. A network function can be realized in different ways, e.g., as a network element on a dedicated hardware, or as a software instance running on a dedicated hardware, or as a virtualized function instantiated on shared (cloud) infrastructure.

The salient features of 5G core network are as follows:

- a) Separation of Control Plane and User Plane
- b) Service Based Architecture (SBA)
- c) Network Slicing support
- d) Enable usage of Network Function Virtualization (NFV) and Software Defined Networking (SDN)

- e) Access Agnostic
- f) Framework for policy control and support of Quality of Service (QoS)
- g) Secure exposure of network function capabilities to 3rd party providers
- h) Storage of subscription data, subscriber access authentication, authorization and security anchoring
- i) Support for “stateless” NFs and storage of their unstructured data in UDSF

In an SBA framework, the individual elements are defined as Network Functions (NFs) instead of Network entities. Through Service Based Interface (SBI), an NF consumes services offered by other NFs. RESTful Application Programming Interfaces (APIs) are used in 5G SBA which use Hypertext Transfer Protocol (HTTP)/2 as the application layer protocol. Service based architecture for the 5G system is shown in Figure 1 including some important core network functions. For the sake of clarity & simplicity, all NFs are not shown.

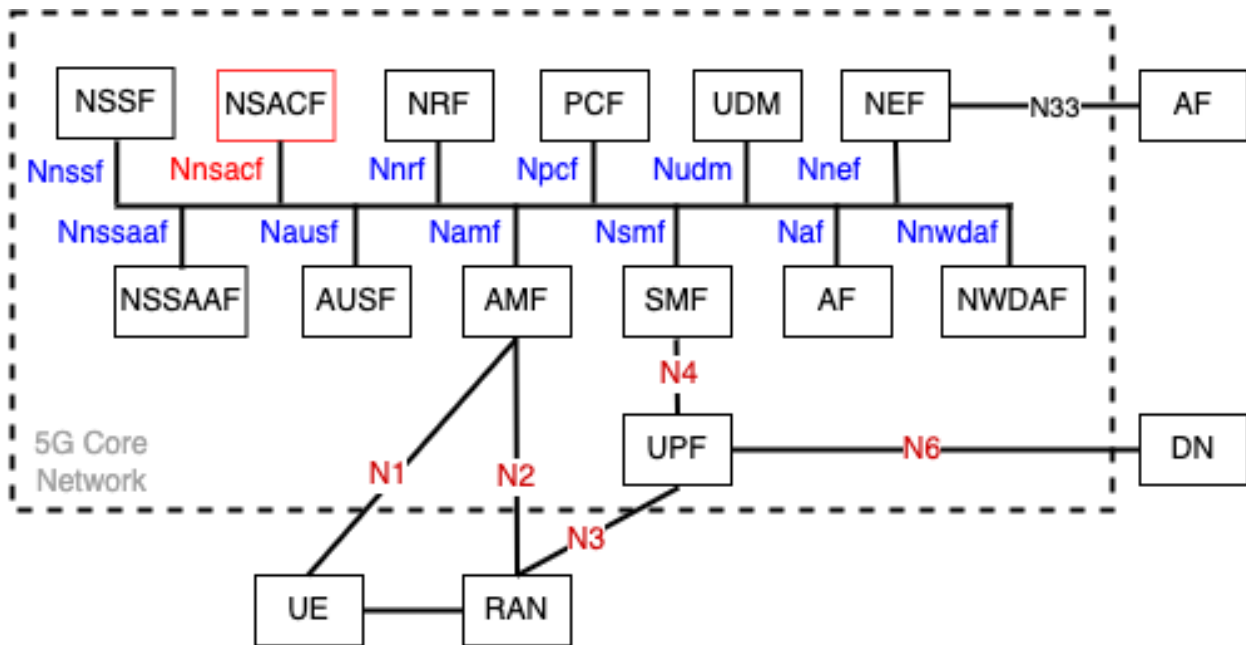

Figure 1: Service based architectural view of 5GS [Adapted from TSDSI STD T1.3GPP 23.501 17.7.0 V1.3.0]

Figure 2 shows reference point representation for a few functions of the core network. Point to point reference points are shown between two network functions, for example N80 between AMF and NSACF.

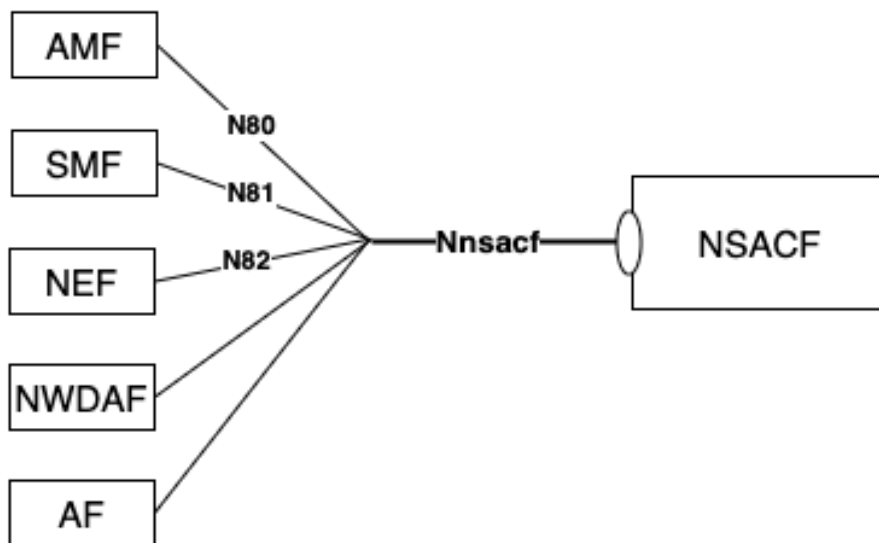
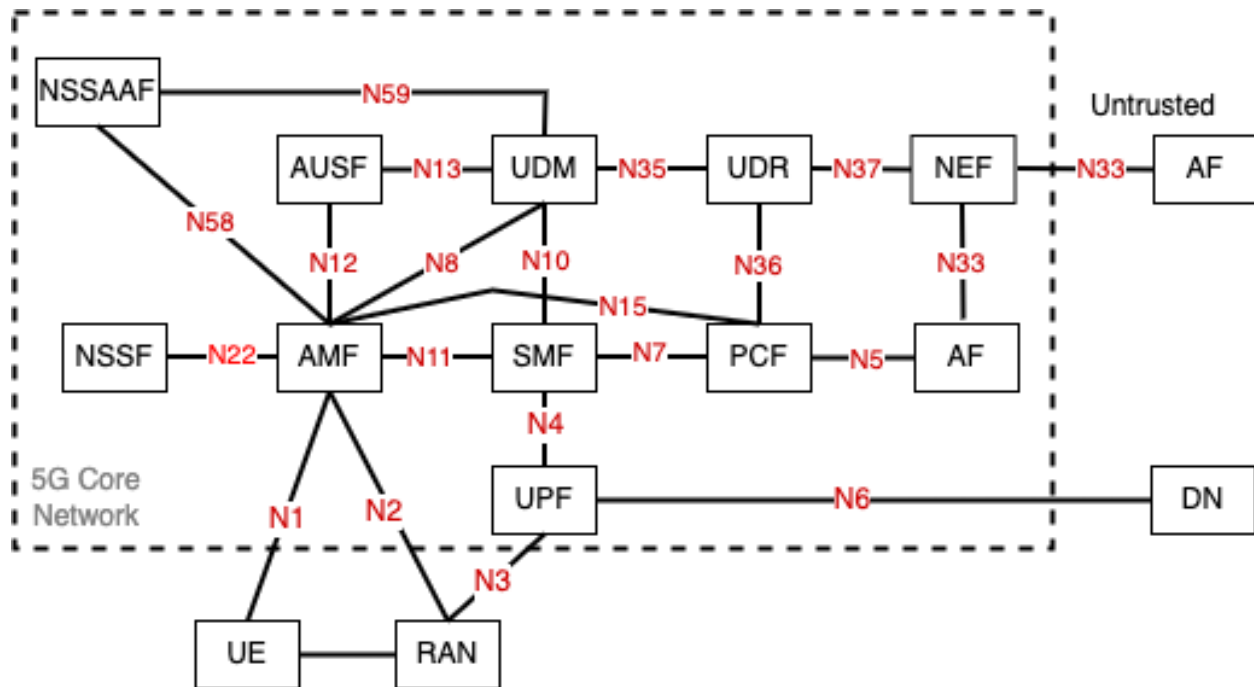

Figure 2: Reference point representation for 5GS [Adapted from TSDSI STD T1.3GPP 23.501 17.7.0 V1.3.0 and 3GPP 29.536 17.3.0]

Some of the core network functions and their functionalities are as follows:

1) Access and Mobility Management Function (AMF): Some of the functionalities of AMF are registration management, connection management, mobility management, access

authentication and authorization, termination of Non-Access Stratum (NAS) and support for Short Message Service (SMS).

2) Session Management Function (SMF): Some of the functionalities of SMF are session establishment, modification and release, UE Internet Protocol (IP) address allocation and management, charging data collection and termination of interfaces towards Policy Control Function (PCF).

3) Authentication Server Function (AuSF): AuSF resides in the Home Network. It supports UE authentication for 3GPP and non-3GPP accesses.

4) User Plane Function (UPF): Some of the UPF functionalities include packet routing and forwarding, policy enforcement and QoS handling (related to user plane part) and traffic usage reporting for user planes. It is the anchor point for UE in case of Intra or Inter RAT mobility.

5) Application Function (AF): It interacts with the 3GPP Core Network to provide services, influences traffic routing by accessing Network Exposure Function (NEF) (and possibly PCF) and by interacting with the policy framework for policy control. In case of existence of more than one PCF in the CN, it reaches the concerned PCF through Binding Support Function (BSF).

6) Network Exposure Function (NEF): Some of the functionalities of NEF are exposure of capabilities, events and analytics, and secure provisioning of information from external applications to the 5G network.

7) Network Repository Function (NRF): NRF supports service discovery function and maintains NF profiles of available NF instances and their supported services. It receives NF discovery request from NF instances and provides information of the discovered NF instances to them.

8) Policy Control Function (PCF): PCF functionalities include support for a unified policy framework to govern the network behavior. PCF provides policy rules to control plane for enforcement and accesses subscription information relevant to policy decisions from UDR.

9) Unified Data Management (UDM): Some of the UDM functionalities are user identification handling, access authorization based on subscription data and UE's serving NF registration management.

10) Network Slice Admission Control Function (NSACF): NSACF is a 5GC NF that monitors and controls the no. of registered UEs and no. of established PDU sessions per network slice which are subject to NSAC. It provides services via service-based interface through API calls to AMF, SMF (or combined SMF+PGW-C), NWDAF and NEF within 5GC. It also provides event-based network slice status notifications and reports to other consumer NFs for monitoring or triggering event-based actions.

Any network function in the control plane can enable other authorized network functions to access their services using standard service-based interfaces.

1.3 General Security Architecture for 5G System

The 5G System works on the principle of service based architecture which presents the need for consideration of security aspects. Secure interactions between the network functions are governed by the security features, i.e. Confidentiality, Integrity and Availability. The architecture enabling secure communications between the network entities is shown in Figure 3.

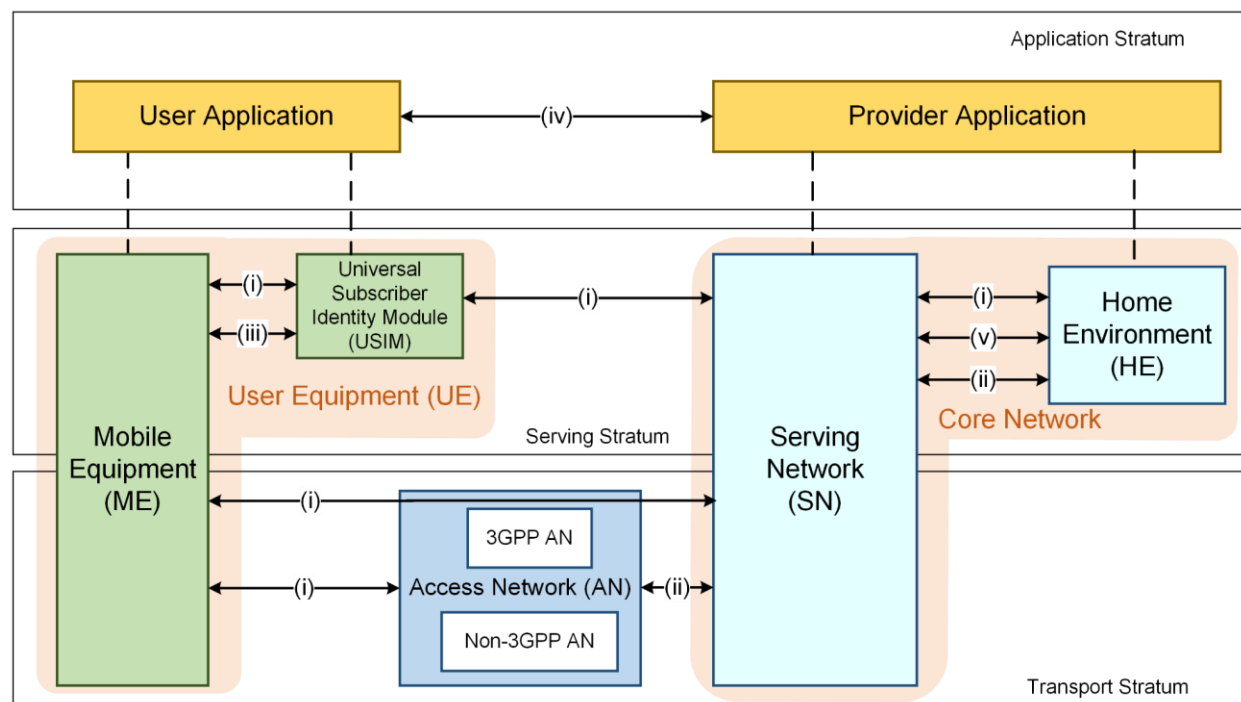

Figure 3: Overview of the security architecture [Adapted from TSDSI STD T1.3GPP 33.501-17.7.0 V1.1.0]

Mobile Equipment (ME) is served by 3GPP and Non-3GPP access networks to facilitate connectivity with the Core Network. When MEs are outside the coverage area of the Home

Environment (their primary service provider), they are served by the Visiting Network (as Serving Network). When the ME is in the coverage area of its primary service provider, there will be no distinction between the Serving Network (SN) and Home Environment (HE), they will be one and the same. ME's communication with the provider network is enabled using the Universal Subscriber Identity Module (USIM).

User Application is the application layer in the UE, which facilitates user interaction with provider application. Provider Application communicates with the user application using the logical link established through the 5G System.

The security features and the security mechanisms for the 5G System and the 5G Core can be categorized in following domains:

(i) **Network Access security:** UEs are authenticated and provided access to the network using security features of this domain. It provides secure access via the 3GPP and non-3GPP networks, in particular protects radio interfaces against attacks. In addition, it includes security context delivery from Serving Network (SN) to Access Network (AN) to support access security.

(ii) **Network Domain security:** The security features of this domain allow network nodes to securely exchange signalling data and user plane data.

(iii) **User domain security:** Users can securely access the mobile equipment using security features of this domain.

(iv) **Application domain security:** The features of this security domain facilitates secure exchange of messages between applications in user domain and provider domain.

(v) **SBA domain security:** The security features of this domain facilitate secure communication between NFs over the service based interfaces within the serving network domain and with other network domains.

(vi) **Visibility and configurability of security:** The security features of this domain provide information about availability of security features to the user. This domain is not shown in the figure.

Common and specific security requirements of NSACF are covered in the present document. The following sections cover the overview of NSACF along with its security aspects.

1.4 Network Slice Admission Control Function (NSACF)

The Network Slice Admission Control Function (NSACF) is a 5G core network function introduced in 3GPP release 17 as part of enhancement of network slicing to support some parameters (related to slice quota management) of GST (Generic Slice Template) as documented in GSMA NG.116. It is supposed to be a non-mandatory NF. It supports the following functionalities:

- Monitoring and controlling the number of registered UEs per network slice.
- Monitoring and controlling the number of established PDU Sessions per network slice.
- Event based Network Slice status notification and reports to a consumer NF.

NSACF is deployed per service area basis and is configured with the maximum number of UEs and/or the maximum number of PDU Sessions allowed to be served per S-NSSAI (Single Network Slice Selection Assistance Information) subject to NSAC.

From data storage perspective, NSACF may have to store/configure below data. This may be done with database or without database, which is implementation dependent/OEM's design choice.

- 1) UE ID
- 2) Access Type
- 3) S-NSSAI(s)
- 4) NF ID
- 5) Update Flag
- 6) Current UE count per network slice
- 7) Max. UE count per network slice
- 8) Current PDU sessions count per network slice
- 9) Max. PDU sessions count per network slice
- 10) EAC (Early Admission Control) Mode- enabled/disabled for S-NSSAI(s)
- 11) Notification and Reports subscriptions of consumer NFs
- 12) Historical usage data (retention is operator dependent)

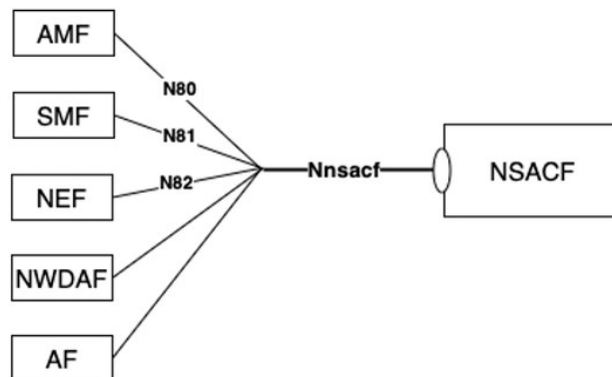

Figure 3. NSACF Service exposure via Nnsacf SBI [Courtesy: 3GPP 29.536-17.3.0]

1.5 NSACF Security Aspects

NSACF is primarily part of the Home Environment, and has no direct communication links with the SN when the user is connected via the visiting network / visiting PLMN. Network Access security is not applicable in the case of NSACF, since NSACF isn't responsible for security context delivery. SBA Domain security aspects are the same in the case of NSACF as it receives the control plane data through the Nnsacf SBI for storage.

To ensure SBA domain security, secure communications via SBI interface is considered. In addition, NSACF may have interfaces with the Operations, Administration and Management (OAM) system to facilitate system administration and maintenance. Security aspects of the interface for OAM are also considered. Furthermore, security of the NSACF database and its storage aspects are also important together with secure transfer of the integrity and confidentiality protected reports data to consumer NF.

Chapter 2 - Common Security Requirements

Section 2.1: Access and Authorization

2.1.1 Authentication for Product Management and Maintenance interfaces

Requirement:

NSACF shall support mutual authentication of entities on management interfaces, the authentication mechanism can rely on the management protocols used for the interface or other means.

Secure cryptographic controls prescribed in Table 1 of the latest document “Indian Telecommunication Security Assurance Requirements (ITSAR) for Cryptographic Controls” shall only be used for NSACF management and maintenance.

[Ref [3]: TSDSI STD T1.3GPP 33.117 17.2.0 V1.2.0 Section 4.2.3.4.4.1]

2.1.2 Management Traffic Protection

Requirement:

NSACF management traffic (information exchanged during interactions with OAM) shall be protected strictly using secure cryptographic controls prescribed in Table 1 of the latest document “ITSAR For Cryptographic Controls” only.

[Ref [3]: TSDSI STD T1.3GPP 33.117 17.2.0 V1.2.0 Section 4.2.3.2.4]

2.1.3 Role-based access control policy

Requirement:

NSACF shall support Role-Based Access Control (RBAC). A role-based access control system uses a set of controls that determines how users interact with domains and resources. The RBAC system controls how users or groups of users are allowed access to the various domains (the domains could be Fault Management, Performance Management, System Admin, etc.) and what type of operation they can perform, i.e. the specific operation command or command group (e.g., View, Modify, Execute). NSACF shall support RBAC with a minimum of 3 user roles, in particular, for OAM privilege management for NSACF Management and Maintenance, including authorization of the operation for configuration data and software via NSACF console interface.

[Ref [3]: TSDSI STD T1.3GPP 33.117 17.2.0 V1.2.0 Section 4.2.3.4.6.2]

Note: The reference to Console interface may not be applicable here for Generalized Virtual Network Product (GVNP) Models of Type 1 & 2

2.1.4 User authentication - Local/Remote

Requirement:

The various user and machine accounts on a system shall be protected from misuse. To this end, an authentication attribute is typically used, which, when combined with the username, enables unambiguous authentication and identification of the authorized user.

Authentication attributes include

- a) Cryptographic keys
- b) Token
- c) Passwords

This means that authentication based on a parameter that can be spoofed (e.g., phone numbers, public IP addresses or Virtual Private Network (VPN) membership) is not permitted. Exceptions are attributes that cannot be faked or spoofed by an attacker. Minimum two of the above Authentication attributes shall be mandatorily combined for protecting all the accounts from misuse. An exception to this requirement is local access and machine accounts where at least one authentication attribute shall be supported.

[Ref [3]: TSDSI STD T1.3GPP 33.117 17.2.0 V1.2.0 Section 4.2.3.4.2.1]

2.1.5 Remote login restrictions for privileged users

Requirement:

Direct Login to NSACF as root or equivalent highest privileged user shall be limited to the system console only. Root user will not be allowed to login to NSACF remotely.

This remote root user access restriction is also applicable to application software's / tools such as TeamViewer, desktop sharing which provide remote access to the NSACF.

[Ref [3]: TSDSI STD T1.3GPP 33.117 17.2.0 V1.2.0 Section 4.3.2.6]

Note: This clause may not be applicable to GVNP Type-1

2.1.6 Authorization Policy

Requirement:

The authorizations for accounts and applications shall be reduced to the minimum required for the tasks they have to perform.

Authorizations to a system shall be restricted to a level in which a user can only access data and use functions that he needs in the course of his work. Suitable authorizations shall also be assigned for access to files that are components of the operating system or of applications or that are generated by the same (e.g., configuration and logging files).

Alongside access to data, execution of applications and components shall also take place with rights that are as low as possible. Applications should not be executed with administrator or system rights.

[Ref [3]: TSDSI STD T1.3GPP 33.117 17.2.0 V1.2.0 Section 4.2.3.4.6.1]

2.1.7 Unambiguous identification of the user & group accounts

Requirement:

Users shall be identified unambiguously by the NSACF.

NSACF shall support the assignment of individual accounts per user, where the user could be a person, or, for Machine Accounts, an application, or a system.

NSACF shall not enable the use of group accounts or group credentials, or sharing of the same account between several users.

[Ref [3]: TSDSI STD T1.3GPP 33.117 17.2.0 V1.2.0 Section 4.2.3.4.1.2]

Section 2.2: Authentication Attribute Management

2.2.1 Authentication Policy

Requirement:

The usage of a system function without successful authentication on the basis of the user identity and at least two authentication attributes shall be prevented. For machine accounts

and local access one authentication attribute will be sufficient. System functions comprise, for example network services (like Secure Shell (SSH), Secure File Transfer Protocol (SFTP), Web services), local access via a management console, local usage of operating system and applications. This requirement shall also be applied to accounts that are only used for communication between systems.

[Ref [3]: TSDSI STD T1.3GPP 33.117 17.2.0 V1.2.0 Section 4.2.3.4.1.1]

Note: The reference to 'Local access' and 'Console' may not be applicable here for GVNP Models of Type 1 & 2

2.2.2 Authentication Support - External

Requirement:

If the NSACF supports external authentication mechanism such as AAA server (for authentication, authorization and accounting services), then the communication between NSACF and the external authentication entity shall be protected using the authentication and related service protocols built strictly using the Secure cryptographic controls prescribed in Table 1 of the latest document "ITSAR for Cryptographic Controls" only.

2.2.3 Protection against brute force and dictionary attacks

Requirement:

Protection against brute force and dictionary attacks that hinder authentication attribute (i.e. password) guessing shall be implemented in NSACF.

Brute force and dictionary attacks aim to use automated guessing to ascertain authentication attributes for user and machine accounts.

Various measures or a combination of the following measures can be taken to prevent this:

- a) Using the timer delay (this delay could be the same or increased depending on the operator's policy for each attempt) for each newly entered password input following an incorrect entry ("tar pit").
- b) Blocking an account following a specified number of incorrect attempts. However, it has to be taken into account that this solution needs a process for unlocking and an attacker can force this to deactivate accounts and make them unusable.
- c) Using an authentication attribute blacklist to prevent vulnerable passwords.
- d) Using Completely Automated Public Turing test to tell Computers and Humans Apart (CAPTCHA) to prevent automated attempts (often used for Web applications).

In order to achieve higher security, two or more of the measures indicated above shall be mandatorily supported by NSACF. An exception to this requirement is machine accounts.

[Ref [3]: TSDSI STD T1.3GPP 33.117 17.2.0 V1.2.0 Section 4.2.3.4.3.3]

2.2.4 Enforce Strong Password

Requirement:

- a) The configuration setting shall be such that NSACF shall only accept passwords that comply with the following complexity criteria:
 - i) Absolute minimum length of 8 characters (shorter lengths shall be rejected by the NSACF). It shall not be possible setting this absolute minimum length to a lower value by configuration.
 - ii) Password shall mandatorily comprise all the following four categories of characters:
 - 1) At least 1 uppercase character (A-Z)
 - 2) At least 1 lowercase character (a-z)
 - 3) At least 1 digit (0-9)
 - 4) At least 1 special character (e.g., @;!.)
- b) The minimum length of characters in the passwords and the set of allowable special characters shall be configurable by the operator. The special characters may be categorized in sets according to their Unicode category.
- c) If a central system is used for user authentication password policy, then additional assurance shall be provided that the central system enforces the same password complexity rules as laid down for the local system in this sub-clause.
- d) If a central system is not used for user authentication, the assurance on password complexity rules shall be performed on the NSACF.
- e) When a user is changing a password or entering a new password, NSACF /central system checks and ensures that it meets the password requirements. Above requirements shall be applicable for all passwords used (e.g., application-level, OS-level, etc.). Passwords shall not be stored in clear text in the system; passwords shall be salted and hashed.

[Ref [3]: TSDSI STD T1.3GPP 33.117 17.2.0 V1.2.0 Section 4.2.3.4.3.1]

2.2.5 Inactive Session timeout

Requirement:

An OAM user interactive session shall be terminated automatically after a specified period of inactivity. It shall be possible to configure an inactivity time-out period.

NSACF shall monitor inactive sessions of administrative login users and initiate session locking mechanism based on pre-configured timers. Unlocking the session shall be permissible only by user authentication. If the inactivity period further continues for a defined period, session /user ID timeout must occur after this inactivity.

Reauthentication of the OAM user shall be repeated following any period of inactivity lasting 15 minutes or longer.

[Ref [3]: TSDSI STD T1.3GPP 33.117 17.2.0 V1.2.0 Section 4.2.3.5.2]

2.2.6 Password Changes

Requirement:

If a password is used as an authentication attribute, then the system shall offer a function that enables a user to change his password at any time. When an external centralized system for user authentication is used, it shall be possible to implement this function on this system.

Password change shall be enforced after initial login (after successful authentication).

NSACF shall enforce password change based on password management policy. In particular, the system shall enforce password expiry. NSACF shall support a configurable period for expiry of passwords.

Previously used passwords shall not be allowed up to a certain number (Password History).

The number of disallowed previously used passwords shall be:

- a) Configurable;
- b) Greater than 0;
- c) And its minimum value shall be 3. This means that the NSACF shall store at least the three previously set passwords. The maximum number of passwords that the NSACF can store for each user is up to the manufacturer.

When a password is about to expire, a password expiry notification shall be provided to the user.

Above requirements shall be applicable for all passwords used (e.g., application-level, OS-level, etc.). An exception to this requirement is machine accounts.

NSACF to have an in-built mechanism to support this requirement.

If a central system is used for user authentication password policy, then additional assurance shall be provided that the central system enforces the same password change policies as laid down for the local system in this subclause.

And if a central system is not used for user authentication, the assurance on password changes rules shall be performed on the NSACF.

The minimum password age shall be set as one day i.e., recycling or flipping of passwords to immediate return to favorite password is not possible.

The password shall be changed (need not be automatic) based on key events including, not limited to

- Indication of compromise (IoC)
- Change of user roles
- When a user leaves the organization

[Ref [3]: TSDSI STD T1.3GPP 33.117 17.2.0 V1.2.0 Section 4.2.3.4.3.2]

[Ref [25]: CIS_Benchmarks_Password_Policy_Guide_v21.12]

2.2.7 Protected Authentication feedback

Requirement:

The Authentication attribute shall not be displayed in such a way that it could be seen and misused by a casual local observer. Typically, the individual characters of the password are replaced by a character such as "*".

This requirement shall be applicable for all passwords used (e.g., application-level, OS-level, etc.)._An exception to this requirement is machine accounts.

[Ref [3]: TSDSI STD T1.3GPP 33.117 17.2.0 V1.2.0 Section 4.2.3.4.3.4]

2.2.8 Removal of predefined or default authentication attributes

Requirement:

Predefined or default authentication attributes shall be deleted or disabled. Normally, authentication attributes such as password or cryptographic keys will be pre-configured

from the producer, Original Equipment Manufacturer (OEM) or developer of a system. Such authentication attributes shall be changed by automatically forcing a user to change it on 1st time login to the system or the OEM provides instructions on how to manually change it.

[Ref [3]: TSDSI STD T1.3GPP 33.117 17.2.0 V1.2.0 Section 4.2.3.4.2.3]

2.2.9 Logout function

Requirement:

The system shall have a function that allows a signed-in user to logout at any time. All processes under the logged-in user ID shall be terminated on logout. NSACF shall be able to continue to operate without interactive sessions.

Only for debugging purposes, processes under a logged-in user ID may be allowed to continue to run after detaching the interactive session.

[Ref [3]: TSDSI STD T1.3GPP 33.117 17.2.0 V1.2.0 Section 4.2.3.5.1]

2.2.10 Policy regarding consecutive failed login attempts

Requirement:

- a) The maximum permissible number of consecutive failed user account login attempts shall be configurable by the operator. The definition of the default value set at manufacturing time for the maximum number of failed user account login attempts shall be less than or equal to 8, typically 5. After the maximum permissible number of consecutive failed user account login attempts is exceeded by a user, there shall be a block delay in allowing the user to attempt login again. This block delay and the capability to set the period of the block delay, e.g., double the delay, or 5 minutes delay, or 10 minutes delay, after each login failure should be configurable by the operator. The default value set at manufacturing time for this delay shall be greater than or equal to 5 sec.
- b) If supported, infinite (permanent) locking of an account that has exceeded the maximum permissible number of consecutive failed user account login attempts shall also be possible via configuration, with the exception of administrative accounts, which shall get only temporarily locked.

[Ref [3]: TSDSI STD T1.3GPP 33.117 17.2.0 V1.2.0 Section 4.2.3.4.5]

2.2.11 Suspend accounts on non-use

Requirement:

It shall be possible for the system to automatically suspend an account after 'X' days without a valid login.

Note: X may be specified by operator. It can be implemented centrally also.

[Ref [34]: CIS Password Policy Guide]

Section 2.3: Software Security

2.3.1 Secure Update

Requirement:

- a) Software package integrity shall be validated during the software update stage.
- b) NSACF shall support software package integrity validation via cryptographic means, e.g., digital signature using Secure cryptographic controls prescribed in Table 1 of the latest document "ITSAR for Cryptographic Controls" only. To this end, the NSACF has a list of public keys or certificates of authorised software sources, and uses the keys to verify that the software update originated from only these sources.
- c) Tampered software shall not be executed or installed if integrity check fails.
- d) A security mechanism is required to guarantee that only authorized individuals can initiate and deploy a software update and modify the list mentioned in (b) above.

Note: Code signing (valid and not time expired) is also allowed as an option in (b) above.

[Ref [3]: TSDSI STD T1.3GPP 33.117 17.2.0 V1.2.0 Section 4.2.3.3.5]

2.3.2 Secure Upgrade

Requirement:

- a) Software package integrity shall be validated during the software upgrade stage.
- b) NSACF shall support software package integrity validation via cryptographic means, e.g., digital signature using Secure cryptographic controls prescribed in Table 1 of the latest document "ITSAR for Cryptographic Controls" only. To this end, the NSACF has a list of public keys or certificates of authorised software sources, and uses the keys to verify that the software upgrade originated from only these sources.
- c) Tampered software shall not be executed or installed if integrity check fails.

- d) A security mechanism is required to guarantee that only authorized individuals can initiate and deploy a software upgrade and modify the list mentioned in (b) above.

Note: Code signing (valid and not time expired) is also allowed as an option in (b) above.

[Ref [3]: TSDSI STD T1.3GPP 33.117 17.2.0 V1.2.0 Section 4.2.3.3.5]

2.3.3 Source code security assurance

Requirement:

- a) OEM shall follow best security practices including secure coding for software development. Source code shall be made available either at Telecom Security Testing Laboratory (TSTL) premises or at the mutually agreed location for source code review by the designated TSTL. It may be supported by furnishing the Software Test Document (STD).
- b) Also, OEM shall submit the undertaking as below:
 - i) Industry standard best practices of secure coding have been followed during the entire software development life cycle of the NSACF software which includes OEM developed code, third party software and open source code libraries used/embedded in the NSACF.
 - ii) NSACF software shall be free from Common Weakness Enumeration (CWE) top 25, Open Worldwide Application Security Project (OWASP) top 10 security vulnerabilities and OWASP top 10 API Security vulnerabilities as on the date of latest release of product or three months prior to the date of offer of product for testing, whichever is latest. For security weaknesses, vulnerabilities identified or discovered during the interim period, OEM shall give mitigation plan.
 - iii) The binaries for NSACF and upgrades/updates thereafter generated from the source code are free from all known security vulnerabilities stated in (ii) above.

[Ref [4]: https://cwe.mitre.org/top25/archive/2022/2022_cwe_top25.html]

[Ref [5]: <https://owasp.org/www-project-top-ten/>]

[Ref [6]: <https://owasp.org/www-project-api-security/>]

2.3.4 Known Malware and backdoor Check

Requirement:

OEM shall submit an undertaking stating that NSACF is free from all known malware and backdoors as on the date of offer of NSACF to designated TSTL for testing and shall submit their internal Malware Test Document (MTD) of the NSACF to the designated TSTL.

2.3.5 No unused software

Requirement:

Software components or parts of software which are not needed for operation or functionality of the NSACF shall not be present/configured.

Orphaned software components /packages shall not be present in NSACF.

OEM shall provide the list of software that are necessary for NSACF's operation. In addition, OEM shall furnish an undertaking as "NSACF does not contain software that is not used in the functionality of NSACF."

[Ref [3]: TSDSI STD T1.3GPP 33.117 17.2.0 V1.2.0 Section 4.3.2.3]

2.3.6 Unnecessary Services Removal

Requirement:

NSACF shall only run protocol handlers and services which are needed for its operation, and which do not have any known security vulnerabilities. In particular, by default the following services shall be initially configured to be disabled on NSACF by the vendor except if services are needed during deployment. In that case those services shall be disabled according to vendor's instructions after deployment is done. Disabled protocols may still need to be enabled for other reasons by the operators, e.g., remote diagnostics.

NSACF shall not support following services:

- a) File Transfer Protocol (FTP)
- b) Trivial File Transfer Protocol (TFTP)
- c) Telnet
- d) rlogin, Rate Control Protocol (RCP), Remote Shell Protocol (RSH)
- e) HTTP
- f) Simple Network Management Protocol (SNMP) v1 and v2
- g) SSHv1
- h) Transmission Control Protocol (TCP) / User Datagram Protocol (UDP) Small Servers (Echo, Chargen, Discard and Daytime)
- i) Finger
- j) Bootstrap Protocol (BOOTP) server

- k) Discovery protocols (Cisco Discovery Protocol (CDP), Link Layer Discovery Protocol (LLDP))
- l) IP Identification Service (Identd)
- m) Packet Assembler/Disassembler (PAD)
- n) Maintenance Operations Protocol (MOP)

Any other protocols, services that are vulnerable are also to be permanently disabled. Full documentation of required protocols and services (communication matrix) of the NSACF and their purpose needs to be provided by the OEM as a prerequisite for the test case.

[Ref [3]: TSDSI STD T1.3GPP 33.117 17.2.0 V1.2.0 Section 4.3.2.1]

2.3.7 Restricting System Boot Source

Requirement:

The NSACF can boot only from the memory devices intended for this purpose.

[Ref [3]: TSDSI STD T1.3GPP 33.117 17.2.0 V1.2.0 Section - 4.2.3.3.2]

Note: This may not be applicable here for GVNP Models of Type 1 & 2.

2.3.8 Secure Time Synchronization

Requirement:

NSACF shall establish a secure communication channel through standard interface with the Network Time Protocol (NTP) / Precision Time Protocol (PTP) server as per appropriate TEC ER (essential requirement) document.

NSACF shall establish a secure communication channel strictly using Secure cryptographic controls prescribed in Table 1 of the latest document “ITSAR for Cryptographic Controls” with NTP/PTP server.

NSACF shall generate audit logs for all changes to time settings.

Note: RFC 8915 which proposes Network Time Security (NTS) as an extension field for the NTP version 4 is also permitted.

2.3.9 Restricted reachability of services

Requirement:

NSACF shall restrict the reachability of services so that they can only be reached on interfaces meant for the purpose. On interfaces where services are active, the reachability should be limited to legitimate communication peers. This limitation shall be realized on the NSACF itself (without measures (e.g., firewall) at network side) according to the requirement detailed in section 2.7.1 Traffic Filtering.

Administrative services (e.g., SSH, HyperText Transfer Protocol Secure (HTTPS), Remote Desktop Protocol (RDP)) shall be restricted to interfaces in the management plane to support separation of management traffic from user traffic.

[Ref [3]: TSDSI STD T1.3GPP 33.117 17.2.0 V1.2.0 Section 4.3.2.2]

2.3.10 Self Testing

Requirement:

The NSACF's cryptographic module shall perform power-up self-tests and conditional self-tests to ensure that the module is functioning properly. Power-up self-tests shall be performed when the cryptographic module is powered up during System bootup/restart. Conditional self-tests shall be performed when an applicable security function or operation is invoked (i.e. security functions for which self-tests are required). If a cryptographic module fails a self-test, the module shall enter an error state and output an error indicator via the status output interface. The cryptographic module shall not perform any cryptographic operations while in an error state.

Section 2.4: System Secure Execution Environment

2.4.1 No unused functions

Requirement:

Unused functions i.e. the software and hardware functions which are not needed for operation or functionality of the NSACF shall be permanently deactivated. Permanently means that they shall not be reactivated again after the NSACF system's reboot. If unused functions of software cannot be deleted or uninstalled individually as required in clause "2.3.5 No unused software" of the present document, such functions shall be deactivated in the configuration of NSACF permanently.

The list of hardware and software functions installed in the system shall match with the ones that have been mentioned and deemed necessary for the operation of the NSACF.

EXAMPLE: A debugging function in software which can be used for troubleshooting shall not be activated during normal operation of the NSACF.

[Ref [3]: TSDSI STD T1.3GPP 33.117 17.2.0 V1.2.0 Section 4.3.2.4]

Note: The reference to hardware may not be applicable here for GVNP Models of Type 1 & 2.

2.4.2 No unsupported components

Requirement:

OEM to ensure that the NSACF shall not contain software and hardware components that are no longer supported by them or their 3rd Parties (e.g., vendor, producer or developer) including the opensource communities, such as components that have reached end-of-life or end-of-support. An undertaking in this regard shall be provided by OEM.

[Ref [3]: TSDSI STD T1.3GPP 33.117 17.2.0 V1.2.0 Section 4.3.2.5]

Note: The reference to hardware may not be applicable here for GVNP Models of Type 1 & 2.

2.4.3 Avoidance of Unspecified mode of Access

Requirement:

NSACF shall not contain any access mechanism which is unspecified or not declared. An undertaking shall be given by the OEM as follows:

The NSACF shall not contain any wireless, optical, magnetic or any other component that may be used as a covert channel.

Section 2.5: User Audit

2.5.1 Audit trail storage and protection

Requirement:

The security event log shall be access-controlled (file access rights) so only privileged users have access to the log files.

[Ref [3]: TSDSI STD T1.3GPP 33.117 17.2.0 V1.2.0 Section 4.2.3.6.3]

2.5.2 Audit Event Generation

Requirement:

NSACF shall log all important Security events with unique System Reference details as given in the table below.

NSACF shall record within each audit record at least information pertaining to date and time of the event, type of event, subject identity, protocol, service or program used for access, source and destination IP addresses & ports and the outcome (success or failure) of the event.

Additional audit record information, depending on the audit event, shall also be provided as given in the Table below:

Sr. No.	Event Types (Mandatory or Optional)	Description	Event data to be logged
1.	Incorrect login attempts (Mandatory)	Records any user's incorrect login attempts to the NSACF	Username Source (IP address) if remote access Outcome of event (Success or failure) Timestamp
2.	Administrator access (Mandatory)	Records any access attempts to accounts that have system privileges.	Username Timestamp Length of session Outcome of event (Success or failure) Source (IP address) if remote access
3.	Account administration (Mandatory)	Records all account administration activity, i.e. configure, delete, copy, enable, and disable.	Administrator username Administered account Activity performed (configure, delete, enable and disable) Outcome of event (Success or failure)

			Timestamp
4.	Resource Usage (Mandatory)	Records events that have been triggered when system parameter values such as disk space, CPU load over a longer period have exceeded their defined thresholds.	Value exceeded
			Value reached
			(Here suitable threshold values shall be defined depending on the individual system.)
			Outcome of event (Success or failure)
			Timestamp
5.	Configuration change (Mandatory)	Changes to configuration of the NSACF	Change made
			Timestamp
			Outcome of event (Success or failure)
			Username
6.	Reboot/shutdown/ crash (Mandatory)	This event records any action on the network device/NSACF that forces a reboot or shutdown OR where the network device/NSACF has crashed.	Action performed (boot, reboot, shutdown, etc.)
			Username (for intentional actions)
			Outcome of event (Success or failure)
			Timestamp
7.	Interface status change (Mandatory)	Change to the status of interfaces on the NSACF (e.g., shutdown)	Interface name and type
			Status (shutdown, down, missing link, etc.)
			Outcome of event (Success or failure)
			Timestamp
8.	Change of group membership or accounts (Optional)	Any change of group membership for accounts	Administrator username
			Administered account
			Activity performed (group added or removed)
			Outcome of event (Success or failure)
			Timestamp

9.	Resetting Passwords (Optional)	Resetting of user account passwords by the Administrator	Administrator username
			Administered account
			Activity performed (configure, delete, enable and disable)
			Outcome of event (Success or failure)
			Timestamp
10.	Services (Optional)	Starting and Stopping of Services (if applicable)	Service Identity
			Activity performed (start, stop, etc.)
			Timestamp
			Outcome of event (Success or failure)
11.	X.509 Certificate Validation (Optional)	Unsuccessful attempt to validate a certificate	Timestamp
			Reason for failure
			Subject identity
			Type of event
12.	Secure update (Optional)	Attempt to initiate manual update, initiation of update, completion of update	User identity
			Timestamp
			Outcome of event (Success or failure)
			Activity performed
13.	Time change (Mandatory)	Change in time settings	Old value of time
			New value of time
			Timestamp
			Origin of attempt to change time (e.g., IP address)
			Subject identity
			Outcome of event (Success or failure)
			User identity
14.			User identity (wherever applicable)

	Session unlocking /termination (Optional)	Any attempts at unlocking of an interactive session, termination of a remote session by the session locking mechanism, termination of an interactive session	Timestamp
			Outcome of event (Success or failure)
			Subject identity
			Activity performed
			Type of event
15.	Trusted Communication paths with IT entities such as Authentication Server, Audit Server, NTP Server, etc. and for authorised remote administrators (Optional)	Initiation, Termination and Failure of trusted Communication paths	Timestamp
			Initiator identity (as applicable)
			Target identity (as applicable)
			User identity (in case of Remote administrator access)
			Type of event
			Outcome of event (Success or failure, as applicable)
16.	Audit data changes (Mandatory)	Changes to audit data including deletion of audit data	Timestamp
			Type of event (audit data deletion, audit data modification)
			Outcome of event (Success or failure)
			Subject identity
			User identity
			Origin of attempt to change time (e.g., IP address)
			Details of data deleted or modified
17.	User Login (Mandatory)	All use of Identification and authentication mechanisms.	User identity
			Origin of attempt (IP address)
			Outcome of event (Success or failure)
			Timestamp

[Ref [3]: TSDSI STD T1.3GPP 33.117 17.2.0 V1.2.0 Section 4.2.3.6.1]

2.5.3 Secure Log Export

Requirement:

- a) NSACF shall support (near real time) forwarding of security event logging data to an external system available in redundant configuration by push or pull mechanism through diverse links.
- b) Log functions should support secure uploading of log files to a central location or to a system external for the NSACF.
- c) NSACF shall be able to store the generated audit data locally. The memory for this purpose shall be dimensioned to cater for the continuous storage of two days of audit data. OEM shall submit justification document for sufficiency of local storage requirement.
- d) Secure Log export shall comply with the secure cryptographic controls prescribed in Table 1 of the latest document “ITSAR for Cryptographic Controls” only.

[Ref [3]: TSDSI STD T1.3GPP 33.117 17.2.0 V1.2.0 Section 4.2.3.6.2]

2.5.4 Logging access to personal data

Requirement:

In some cases, access to personal data in clear text might be required. If such access is required, access to this data shall be logged, and the log shall contain who accessed what data without revealing personal data in clear text. When for practical purposes, such logging is not available, a coarser grain logging is allowed.

In some cases, the personal data stored in the log files may allow the direct identification of a subscriber. In such cases, the revealed personal information may not expose the subscriber to any kind of privacy violation.

[Ref [3]: TSDSI STD T1.33.117-17.1.0 V1.1.0. Section 4.2.3.2.5]

Section 2.6: Data Protection

2.6.1 Cryptographic Based Secure Communication

Requirement:

NSACF shall communicate with the connected entities strictly using the secure cryptographic controls prescribed in Table 1 of the latest document “ITSAR for Cryptographic Controls” only.

OEM shall submit to TSTL, the list of the connected entities with NSACF and the method of secure communication with each entity with details of interface, protocol stack implemented, configuration, detailed procedure of establishing communication with each entity and any other details required for verifying this requirement.

2.6.2 Cryptographic Module Security Assurance

Requirement:

Cryptographic module embedded inside the NSACF (in the form of hardware, software or firmware) that provides all the necessary security services such as authentication, integrity and confidentiality is designed and implemented in compliance with FIPS 140-2 or later as prescribed by NIST standards.

Till further instructions, this clause will be considered 'complied' by submission of an undertaking by the OEM in specified format along with self-certified test reports.

An undertaking is to be submitted by the OEM mentioning that "Cryptographic module embedded inside the NSACF (in the form of hardware, software or firmware) that provides all the necessary security services such as authentication, integrity and confidentiality is designed and implemented in compliance with FIPS 140-2 or later as prescribed by NIST standards."

[Ref [17]: ENISA Recommendation "Standardization in support of the cybersecurity certification", Dec 2019]

[Ref [8]: <https://nvlpubs.nist.gov/nistpubs/FIPS/NIST.FIPS.140-2.pdf>]

2.6.3. Cryptographic Algorithms implementation Security Assurance

Requirement:

Cryptographic algorithm implemented inside the Crypto module of NSACF shall be in compliance with the respective latest FIPS standards (for the specific crypto algorithm).

Till further instructions, this clause will be considered 'complied' by submission of an undertaking by the OEM in specified format along with self-certified test reports.

An undertaking is to be submitted by the OEM mentioning that "Cryptographic algorithms implemented inside the Crypto module of NSACF is in compliance with the respective latest FIPS standards (for the specific crypto algorithm embedded inside the NSACF)."

2.6.4. Protecting data and information – Confidential System Internal Data

Requirement:

- a) When NSACF is in normal operational mode (i.e. not in maintenance mode) there shall be no system function that reveals confidential system internal data in the clear text to users and administrators.

Such functions could be, for example, local or remote OAM CLI or GUI, logging messages, alarms, configuration file exports etc. Confidential system internal data contains authentication data (i.e., PINs, cryptographic keys, passwords, cookies) as well as system internal data that is not required for systems administration.

- b) Access to maintenance mode shall be restricted only to authorized privileged users.

[Ref [3]: TSDSI STD T1.33.117-17.1.0 V1.1.0. Section 4.2.3.2.2.]

2.6.5. Protecting data and information in storage

Requirement:

- a) For sensitive data (persistent or temporary) in storage, read access rights shall be restricted. Sensitive files of NSACF system that are needed for the functionality shall be protected against manipulation strictly using the Secure cryptographic controls prescribed in Table 1 of the latest document “ITSAR for Cryptographic Controls” with appropriate non-repudiation controls.
- b) In addition, the following rules apply for:
 - i) Systems that need access to identification and authentication data in the clear/readable form e.g., in order to perform an activity/operation. Such systems shall not store this data in the clear/readable form, but scramble or encrypt it by implementation-specific means.
 - ii) Systems that do not need access to sensitive data (e.g., user passwords) in the clear. Such systems shall hash this sensitive data strictly using the cryptographic controls prescribed in Table 1 of the latest document “ITSAR for Cryptographic Controls” only.
 - iii) Stored files in the NSACF Shall be protected against manipulation strictly using Secure cryptographic controls prescribed in Table 1 of the latest document “ITSAR for Cryptographic Controls” only.

[Ref [3]: TSDSI STD T1.3GPP 33.117 17.2.0 V1.2.0 Section 4.2.3.2.3]

2.6.6 Protection against Copy of Data

Requirement:

- a) Without authentication & authorization and except for specified purposes, NSACF shall not create a copy of data in use or data in transit.
 - b) Protective measures should exist against use of available system functions / software residing in NSACF to create a copy of data for illegal transmission.
-

2.6.7 Protection against Data Exfiltration - Overt Channel

Requirement:

- a) NSACF shall have mechanisms to prevent data exfiltration attacks for theft of data in use and data in transit.
 - b) Establishment of outbound overt channels such as, HTTPS, Instant Messaging (IM), Peer-to-Peer (P2P), Email etc. are to be forbidden if they are auto-initiated by / auto-originated from the NSACF.
 - c) Session logs shall be generated for establishment of any session initiated by either user or NSACF.
-

2.6.8 Protection against Data Exfiltration - Covert Channel

Requirement:

- a) NSACF shall have mechanisms to prevent data exfiltration attacks for theft of data in use and data in transit (within its boundary).
 - b) Establishment of outbound covert channels and tunnels such as Domain Name System (DNS) Tunnel, HTTPS Tunnel, Internet Control Message Protocol (ICMP) Tunnel, Transport Layer Security (TLS), Secure Sockets Layer (SSL), SSH, Internet Protocol Security (IPSec), Virtual Private Network (VPN), Real-time Transfer Protocol (RTP) Encapsulation etc. are to be forbidden if they are auto-initiated by / auto-originated from the NSACF.
 - c) Session logs shall be generated for establishment of any session initiated by either user or NSACF system.
-

2.6.9 System robustness against unexpected input

Requirement:

During transmission of data to a system it is necessary to validate input to NSACF before processing. This includes all data which is sent to the system. Examples of this are user input, inputs from NSACF's NF consumers, values in arrays and content in protocols. The following typical implementation error shall be avoided:

- a) No validation on the lengths of transferred data
- b) Incorrect assumptions about data formats
- c) No validation that received data complies with the specification
- d) Insufficient handling of protocol errors in received data
- e) Insufficient restriction on recursion when parsing complex data formats
- f) White listing or escaping for inputs outside the values margin

[Ref [3]: TSDSI STD T1.3GPP 33.117 17.2.0 V1.2.0 section 4.2.3.3.4]

2.6.10 Security of backup data

Requirement:

NSACF shall support mechanisms for taking backup of sensitive data, configuration and log files. An effective back up strategy shall be in place and documented.

[Ref [18]: "Security Guidance for 5G Cloud Infrastructure Part III: Data Protection" by NSA & CISA]

2.6.11 Secure deletion of sensitive data

Requirement:

NSACF shall support secure deletion of sensitive data by authorized users in such a manner that it cannot be recovered through any forensic means.

Section 2.7: Network Services

2.7.1 Traffic Filtering – Network Level Requirement

Requirement:

NSACF shall provide a mechanism to filter incoming IP packets on any interface (Refer to RFC 3871)

In particular the NSACF shall provide a mechanism:

- a) To filter incoming IP packets on any IP interface at Network Layer and Transport Layer of the stack ISO/Open Systems Interconnection (OSI).
- b) To allow specified actions to be taken when a filter rule matches. In particular at least the following actions should be supported:
 - i) Discard/Drop: the matching message is discarded, no subsequent rules are applied and no answer is sent back.
 - ii) Accept: the matching message is accepted.
 - iii) Account: the matching message is accounted for i.e. a counter for the rule is incremented. This action can be combined with the previous ones. This feature is useful to monitor traffic before its blocking.
- c) To enable/disable for each rule the logging for Dropped packets, i.e. details on messages matching the rule for troubleshooting.
- d) To filter on the basis of the value(s) of source IP, destination IP and port addresses of the protocol header
- e) To reset the accounting.
- f) NSACF shall provide a mechanism to disable/enable each defined rule.

[Ref [3]: TSDSI STD T1.3GPP 33.117 17.2.0 V1.2.0 Section 4.2.6.2.1]

[Ref [11]: RFC 3871 - Operational Security Requirements for Large Internet Service Provider (ISP) IP Network Infrastructure]

2.7.2 Traffic Separation

Requirement:

The NSACF shall support the physical or logical separation of traffic belonging to different network domains. For example, OAM traffic and control plane traffic belong to different network domains. Refer to RFC 3871 for further information.

[Ref [3]: TSDSI STD T1.3GPP 33.117 17.2.0 V1.2.0 section 4.3.5.1]

[Ref [11]: RFC 3871 - Operational Security Requirements for Large Internet Service Provider (ISP) IP Network Infrastructure]

2.7.3 Traffic Protection – Anti-Spoofing

Requirement:

NSACF shall not process IP packets if their source address is not reachable via the incoming interface. Implementation example: Use of "Reverse Path Filter" (RPF) provides this function.

[Ref [3]: TSDSI STD T1.3GPP 33.117 17.2.0 V1.2.0 section 4.3.3.1.1]

Section 2.8: Attack Prevention Mechanisms

2.8.1 Network level and Application-level DDoS

Requirement:

NSACF shall have protection mechanisms against Network level and Application-level Distributed Denial of Service (DDoS) attacks.

NSACF shall provide security measures to deal with overload situations which may occur as a result of a denial-of-service attack or during periods of increased traffic. In particular, partial or complete impairment of system availability shall be avoided.

Potential protective measures may include:

- a) Restricting available RAM per application
- b) Restricting maximum sessions for a Web/Database application
- c) Defining the maximum size of a dataset
- d) Restricting Central Processing Unit (CPU) resources per process
- e) Prioritizing processes
- f) Limiting amount or size of transactions of an user or from an IP address in a specific time range
- g) Limiting amount or size of transactions to an IP address/Port Address in a specific time range

[Ref [3]: TSDSI STD T1.3GPP 33.117 17.2.0 V1.2.0 Section 4.2.3.3.1]

2.8.2 Excessive Overload Protection

Requirement:

NSACF shall act in a predictable way if an overload situation cannot be prevented. NSACF shall be built in such a way that it can react to an overload situation in a controlled way.

However, it is possible that a situation happens where the security measures are no longer sufficient. In such a case it shall be ensured that NSACF cannot reach an undefined and thus potentially insecure, state. In an extreme case this means that a controlled system shutdown is preferable to uncontrolled failure of the security functions and thus loss of system protection.

OEM shall provide a technical description of the NSACF's overload control mechanisms. (especially whether these mechanisms rely on cooperation of other network elements)

[Ref [3]: TSDSI STD T1.3GPP 33.117 17.2.0 V1.2.0 Section 4.2.3.3.3]

2.8.3 Interface robustness requirements

Requirement:

NSACF shall be not affected in its availability or robustness by incoming packets, from other network elements, that are manipulated or differing the norm. This means that appropriate packets shall be detected as invalid and be discarded. The process shall not be affecting the performance of NSACF. This robustness shall be just as effective for a great mass of invalid packets as for individual or a small number of packets.

Examples of such packets are:

- a) Mass-produced TCP packets with a set Synchronize (SYN) flag to produce half-open TCP connections (SYN flooding attack).
- b) Packets with the same IP sender address and IP recipient address (Land attack).
- c) Mass-produced ICMP packets with the broadcast address of a network as target address (Smurf attack).
- d) Fragmented IP packets with overlapping offset fields (Teardrop attack).
- e) ICMP packets that are larger than the maximum permitted size (65,535 Bytes) of IP version 4 (IPv4) packets (Ping-of-death attack).
- f) Uncorrelated reply packets (i.e. packets which cannot be correlated to any request).

[Ref [3]: TSDSI STD T1.3GPP 33.117 17.2.0 V1.2.0 section 4.2.6.2.2]

Note: This clause may not be applicable for GVNP Type 1.

Section 2.9: Vulnerability Testing Requirements

2.9.1 Fuzzing – Network and Application Level

Requirement:

It shall be ensured that externally reachable services of NSACF are reasonably robust when receiving unexpected input.

[Ref [3]: TSDSI STD T1.3GPP 33.117 17.2.0 V1.2.0 section 4.4.4]

2.9.2 Port Scanning

Requirement:

It shall be ensured that on all network interfaces of NSACF, only documented ports on the transport layer respond to requests from outside the system.

[Ref [3]: TSDSI STD T1.3GPP 33.117 17.2.0 V1.2.0 section 4.4.2]

2.9.3 Vulnerability Scanning

Requirement:

The purpose of vulnerability scanning is to ensure that there are no known vulnerabilities (or that relevant vulnerabilities are identified and remediation plans in place to mitigate them) on the Network Product, both in the OS and in the applications installed, that can be detected by means of automatic testing tools via the Internet Protocol enabled network interfaces.

The vulnerabilities found during the Vulnerability Scanning/Assessment process shall be remediated as below. For other than critical vulnerabilities, OEM shall provide a remediation plan.

Sr. No.	CVSS Score	Severity	Remediation
1	9.0 - 10.0	Critical	To be patched immediately
2	7.0 - 8.9	High	To be patched within a month
3	4.0 - 6.9	Medium	To be patched within three months

4	0.1 - 3.9	Low	To be patched within a year
---	-----------	-----	-----------------------------

Zero-day vulnerabilities shall be remediated immediately or as soon as possible.

[Ref [3]: TSDSI STD T1.3GPP 33.117 17.2.0 V1.2.0 section 4.4.3]

[Ref [9]: <https://nvd.nist.gov/vuln-metrics/cvss>]

[Ref [28]: GSMA NG 133 Cloud Infrastructure Reference Architecture]

Section 2.10: Operating System

2.10.1 Growing Content Handling

Requirement:

- a) Growing or dynamic content shall not influence system functions.
- b) A file system that reaches its maximum capacity shall lead to an event getting logged with appropriate message parameters and shall not stop NSACF from operating properly. Therefore, countermeasures shall be taken to ensure that this scenario is avoided. The countermeasures are usage of dedicated filesystems, separated from main system functions, or quotas, or at least a file system monitoring.

[Ref [3]: TSDSI STD T1.3GPP 33.117 17.2.0 V1.2.0 Section 4.2.4.1.1.1]

2.10.2 Handling of ICMP

Requirement:

Processing of ICMP version 4 (ICMPv4) and ICMP version 6 (ICMPv6) packets which are not required for operation shall be disabled on the NSACF.

In particular, there are certain types of ICMPv4 and ICMPv6 that are not used in most networks, but represent a risk.

ICMP message types which on receipt lead to responses or to configuration changes are not mentioned in this requirement, but they may be necessary to support relevant and specified networking features. Those must be documented.

Certain ICMP types are generally permitted and do not need to be specifically documented. Those are marked as "Permitted" in the table below.

NSACF shall not send certain ICMP types by default but it may support the option to enable utilization of these types (e.g., for debugging) which are marked as "Optional" in below table:

Type (IPv4)	Type (IPv6)	Description	Send	Respond to
0	128	Echo Reply	Optional (i.e. as automatic reply to "Echo Request")	N/A
3	1	Destination Unreachable	Permitted	N/A
8	129	Echo Request	Permitted	Optional
11	3	Time Exceeded	Optional	N/A
12	4	Parameter Problem	Permitted	N/A
N/A	2	Packet Too Big	Permitted	N/A
N/A	135	Neighbor Solicitation	Permitted	Permitted
N/A	136	Neighbor Advertisement	Permitted	N/A

NSACF shall not respond to, or process (i.e. do changes to configuration) under any circumstances certain ICMP message types as marked in the below table.

Type (IPv4)	Type (IPv6)	Description	Send	Respond to	Process (i.e. do changes to configuration)
5	137	Redirect	N/A	N/A	Not Permitted
13	N/A	Timestamp	N/A	Not Permitted	N/A
14	N/A	Timestamp Reply	Not Permitted (i.e. as automatic reply to "Timestamp")	N/A	N/A
N/A	133	Router Solicitation	N/A	Not Permitted	Not Permitted
N/A	134	Router Advertisement	N/A	N/A	Not Permitted

[Ref [3]: TSDSI STD T1.3GPP 33.117 17.2.0 V1.2.0 Section 4.2.4.1.1.2.]

2.10.3 Authenticated Privilege Escalation only

Requirement:

NSACF shall not support privilege escalation method in interactive sessions (both CLI and GUI) which allows a user to gain administrator/root privileges from another user account without re-authentication.

[Ref [3]: TSDSI STD T1.3GPP 33.117 17.2.0 V1.2.0 Section 4.2.4.1.2.1]

2.10.4 System account identification

Requirement:

Each system user account in NSACF shall have a unique User ID (UID) with appropriate non-repudiation controls.

[Ref [3]: TSDSI STD T1.3GPP 33.117 17.2.0 V1.2.0 Section 4.2.4.2.2]

2.10.5 OS Hardening - Minimized kernel network functions

Requirement:

Kernel based network functions not needed for the operation of the network element shall be deactivated.

In particular the following ones shall be disabled by default:

- a) IP Packet Forwarding between different interfaces of the network product.
- b) Proxy Address Resolution Protocol (ARP) (to prevent resource exhaustion attack and man-in-the-middle attacks)
- c) Directed broadcast (to prevent attacks like Smurf, Denial of Service etc.,)
- d) IPv4 Multicast handling. In particular all packets with IP source or destination address belonging to the multicast IP ranges (224.0.0.0 through 239.255.255.255) shall be discarded by default and multicast route caching and forwarding shall be disabled to prevent smurf and fraggle attacks. A configuration option shall be available to enable the IPv4 multicast handling if required.
- e) Gratuitous ARP messages (to prevent ARP Cache Poisoning attacks)

[Ref [3]: TSDSI STD T1.3GPP 33.117 17.2.0 V1.2.0 Section - 4.3.3.1.2]

Note: This clause may not be applicable for GVNP Type 1.

2.10.6 No automatic launch of removable media

Requirement:

NSACF shall not automatically launch any application when a removable media device such as Compact Disk (CD), Digital Versatile Disk (DVD), Universal Serial Bus (USB)-Sticks or USB-Storage drive is connected. If the operating system supports an automatic launch, it shall be deactivated unless it is required to support availability requirements.

[Ref [3]: TSDSI STD T1.3GPP 33.117 17.2.0 V1.2.0 Section - 4.3.3.1.3]

Note: This clause may not be applicable for GVNP Type 1 and 2.

2.10.7 Protection from buffer overflows

Requirement:

NSACF shall support mechanisms for buffer overflow protection. Documentation which describes these buffer overflow mechanisms and also how to check that they have been enabled and/or implemented shall be provided by OEM.

[Ref [3]: TSDSI STD T1.3GPP 33.117 17.2.0 V1.2.0 Section - 4.3.3.1.5]

2.10.8 External file system mount restrictions

Requirement:

If normal users are allowed to mount external file systems (attached locally or via the network), OS-level restrictions shall be set properly in NSACF in order to prevent privilege escalation or extended access permissions due to the contents of the mounted file systems. OS-level restrictions shall apply to normal users against mount / use of removable media devices (e.g., USB drive, CD ROM etc.) for data transfer.

[Ref [3]: TSDSI STD T1.3GPP 33.117 17.2.0 V1.2.0 Section - 4.3.3.1.6]

Note: This clause may not be applicable for GVNP Type 1 and 2.

2.10.9 File-system Authorization privileges

Requirement:

NSACF shall be designed to ensure that only users that are authorized to modify files, data, directories or file systems have the necessary privileges to do so.

[Ref [3]: TSDSI STD T1.3GPP 33.117 17.2.0 V1.2.0 Section - 4.3.2.7]

2.10.10 SYN Flood Prevention

Requirement:

NSACF shall support a mechanism to prevent Syn Flood attacks. This feature shall be enabled by default.

[Ref [3]: TSDSI STD T1.3GPP 33.117 17.2.0 V1.2.0 Section - 4.3.3.1.4]

2.10.11 Handling of IP options and extensions

Requirement:

IP packets with unnecessary options or extension headers shall not be processed. IP options and extension headers (e.g., source routing) are only required in exceptional cases. So, all packets with enabled IP options or extension headers shall be filtered.

[Ref [3]: TSDSI STD T1.3GPP 33.117 17.2.0 V1.2.0 Section - 4.2.4.1.1.3]

2.10.12 Restrictions on running Scripts / Batch-processes

Requirement:

Scheduled tasks for carrying out the activities such as taking the backups, monitoring disk space and system maintenance activities shall be executed by the privileged user such as administrator only. Similarly, NSACF shall have feature to restrict Scripts / Batch-processes / Macros usage among various users. It shall be possible to administratively configure scheduled tasks usage i.e. Cron-Job usage (permit / deny) among various users like Normal users, privileged users.

2.10.13 Restrictions on Soft-Restart

Requirement:

NSACF shall restrict software-based system restart options usage among various users. The software reset / restart either through command or use of key-combinations like CTRL+ALT+DEL is not available to normal users for prevention of unintended / malicious trigger of system reset / restart.

Section 2.11: Web Servers

This entire section of the security requirements is applicable if the NSACF supports **web management interface**.

2.11.1 HTTPS

Requirement:

The communication between NSACF Web client and NSACF Web server shall be protected strictly using the Secure cryptographic controls prescribed in Table 1 of the latest document “ITSAR for Cryptographic Controls” only.

[Ref [3]: TSDSI STD T1.3GPP 33.117 17.2.0 V1.2.0 section 4.2.5.1]

2.11.2 Webserver logging

Requirement:

Access to the webserver (for both successful as well as failed attempts) shall be logged by NSACF.

The web server log shall contain the following information:

- a) Access timestamp
- b) Source (IP address)
- c) Account (if known)
- d) Attempted login name (if the associated account does not exist)
- e) Relevant fields in http request. The Uniform Resource Locator (URL) should be included whenever possible.
- f) Status code of web server response

[Ref [3]: TSDSI STD T1.3GPP 33.117 17.2.0 V1.2.0 section 4.2.5.2]

2.11.3 HTTPS input validation

Requirement:

NSACF web server shall have a mechanism in place to ensure that web application inputs are not vulnerable to command injection or cross-site scripting attacks.

NSACF web server shall validate, filter, escape, and encode user-controllable input before it is placed in output that is used as a web page that is served to other users.

[Ref [3]: TSDSI STD T1.3GPP 33.117 17.2.0 V1.2.0 section 4.2.5.4]

2.11.4 No system privileges

Requirement:

No NSACF web server processes shall run with system privileges. If a process is started by a user with system privileges, execution shall be transferred to a different user without system privileges after the start.

[Ref [3]: TSDSI STD T1.3GPP 33.117 17.2.0 V1.2.0 section 4.3.4.2]

2.11.5 No unused HTTPS methods

Requirement:

HTTPS methods that are not required for NSACF operation shall be deactivated.

[Ref [3]: TSDSI STD T1.3GPP 33.117 17.2.0 V1.2.0 section 4.3.4.3]

2.11.6 No unused add-ons

Requirement:

All optional add-ons and components of the web server shall be deactivated if they are not required for NSACF operation.

In particular, Common Gateway Interface (CGI) or other scripting components, Server Side Includes (SSI), and Web based Distributed Authoring and Versioning (WebDAV) shall be deactivated if they are not required.

[Ref [3]: TSDSI STD T1.3GPP 33.117 17.2.0 V1.2.0 section 4.3.4.4]

2.11.7 No compiler, interpreter, or shell via CGI or other server-side scripting

Requirement:

If CGI or other scripting technology is used, the CGI directory or other corresponding scripting directory shall not include compilers or interpreters.

[Ref [3]: TSDSI STD T1.3GPP 33.117 17.2.0 V1.2.0 section 4.3.4.5]

2.11.8 No CGI or other scripting for uploads

Requirement:

If CGI or other scripting technology is used, the associated CGI/script directory shall not be used for uploads.

[Ref [3]: TSDSI STD T1.3GPP 33.117 17.2.0 V1.2.0 section 4.3.4.6]

2.11.9 No execution of system commands with SSI

Requirement:

If SSI is active, the execution of system commands shall be deactivated.

[Ref [3]: TSDSI STD T1.3GPP 33.117 17.2.0 V1.2.0 section 4.3.4.7]

2.11.10 Access rights for web server configuration

Requirement:

Access rights for NSACF web server configuration files shall only be granted to the owner of the web server process or to a user with system privileges. Implementation example: Delete "read" and "write" access rights for "others." Only grant "write" access to the user who configures the web server.

[Ref [3]: TSDSI STD T1.3GPP 33.117 17.2.0 V1.2.0 section 4.3.4.8]

2.11.11 No default content

Requirement:

Default content (examples, help files, documentation, aliases) that is provided with the standard installation of the NSACF web server shall be removed.

[Ref [3]: TSDSI STD T1.3GPP 33.117 17.2.0 V1.2.0 section 4.3.4.9]

2.11.12 No directory listings

Requirement:

Directory listings (indexing) / "Directory browsing" shall be deactivated.

[Ref [3]: TSDSI STD T1.3GPP 33.117 17.2.0 V1.2.0 section 4.3.4.10]

2.11.13 Web server information in HTTPS headers

Requirement:

The HTTPS header shall not include information on the version of the NSACF web server and the modules/add-ons used.

[Ref [3]: TSDSI STD T1.3GPP 33.117 17.2.0 V1.2.0 section 4.3.4.11]

2.11.14 Web server information in error pages

Requirement:

User-defined error pages and Error messages shall not include version information and other internal information about the NSACF web server and the modules/add-ons used. Error messages shall not include internal information such as internal server names, error codes, etc. Default error pages of the NSACF web server shall be replaced by error pages defined by the OEM.

[Ref [3]: TSDSI STD T1.3GPP 33.117 17.2.0 V1.2.0 section 4.3.4.12]

2.11.15 Minimized file type mappings

Requirement:

File type or script-mappings that are not required for NSACF operation shall be deleted e.g., php, phtml, js, sh, csh, bin, exe, pl, vbe, vbs.

[Ref [3]: TSDSI STD T1.3GPP 33.117 17.2.0 V1.2.0 section 4.3.4.13]

2.11.16 Restricted file access

Requirement:

Restrictive access rights shall be assigned to all files which are directly or indirectly (e.g., via links or in virtual directories) reside in the NSACF web server's document directory.

In particular, the NSACF web server shall not be able to access files which are not meant to be delivered.

[Ref [3]: TSDSI STD T1.3GPP 33.117 17.2.0 V1.2.0 section 4.3.4.14]

2.11.17 HTTP User sessions

Requirement:

To protect user sessions, NSACF web server shall support the following session ID and session cookie requirements:

- a) The session ID shall uniquely identify the user and distinguish the session from all other active sessions.
- b) The session ID shall be unpredictable.
- c) The session ID shall not contain sensitive information in clear text (e.g., account number, social security, etc.).
- d) In addition to the Session Idle Timeout, NSACF web server shall automatically terminate sessions after a configurable maximum lifetime. This maximum lifetime defines the maximum session span. When the maximum lifetime expires, the session shall be closed, the session ID shall be deleted and the user shall be forced to (re)authenticate in the web application and to establish a new session. The default value for this maximum lifetime shall be set to 8 hours.
- e) Session ID's shall be regenerated for each new session (e.g., each time a user logs in).
- f) The session ID shall not be reused or renewed in subsequent sessions.
- g) NSACF shall not use persistent cookies to manage sessions but only session cookies. This means that neither the "expire" nor the "max-age" attribute shall be set in the cookies.
- h) Where session cookies are used the attribute 'HttpOnly' shall be set to true.
- i) Where session cookies are used the 'domain' attribute shall be set to ensure that the cookie can only be sent to the specified domain.
- j) Where session cookies are used the 'path' attribute shall be set to ensure that the cookie can only be sent to the specified directory or sub-directory.
- k) NSACF shall not accept session identifiers from GET/POST variables.
- l) NSACF shall be configured to only accept server generated session ID's.

[Ref [3]: TSDSI STD T1.3GPP 33.117 17.2.0 V1.2.0 section 4.2.5.3]

Section 2.12: General SBA/SBI Aspects

This general baseline requirements are applicable to all Network Functions (NFs) within the 5G Core (5GC) utilizing Service-Based Interfaces (SBI), independent of a specific network product class.

2.12.1 No code execution or inclusion of external resources by JSON parsers

Requirement:

Parsers used by NSACF shall not execute JavaScript or any other code contained in JavaScript Object Notation (JSON) objects received on Service Based Interfaces (SBI). Further, these parsers shall not include any resources external to the received JSON object itself, such as files from the NSACF's filesystem or other resources loaded externally.

[Ref [3]: TSDSI STD T1.3GPP 33.117 17.2.0 V1.2.0 Section - 4.3.6.2]

2.12.2 Validation of the unique key values in Information Elements (IEs)

Requirement:

For data structures where values are accessible using names (sometimes referred to as keys), e.g., a JSON object, the name shall be unique. The occurrence of the same name (or key) twice within such a structure shall be an error and the message shall be rejected.

[Ref [3]: TSDSI STD T1.3GPP 33.117 17.2.0 V1.2.0 Section - 4.3.6.3]

2.12.3 Validation of the IEs limits

Requirement:

The valid format and range of values for each IE, when applicable, shall be defined unambiguously:

- a) For each message the number of leaf IEs shall not exceed 16000.
- b) The maximum size of the JSON body of any HTTP request shall not exceed 16 million bytes.
- c) The maximum nesting depth of leaves shall not exceed 32.

[1. Ref [3]: TSDSI STD T1.3GPP 33.117 17.2.0 V1.2.0 Section - 4.3.6.4

2. Ref[35]: 3GPP TS 29.501 V17.2.0 Principles and Guidelines for Services Definition Stage 3 Section 6.2]

2.12.4 Protection at the transport layer

Requirement:

NF Service Request and Response procedure shall support mutual authentication between NF consumer and NF producer.

All network functions shall support TLS 1.2 or above. Network functions shall support both server-side and client-side certificates.

Authentication between network functions within one PLMN can use the following method:

-

If the PLMN uses protection at the transport layer, authentication provided by the transport layer protection solution shall be used for authentication between NFs.

[Ref [3]: TSDSI STD T1.3GPP 33.117 17.2.0 V1.2.0 Section 4.2.2.2.2]

2.12.5 Authorization token verification failure handling within one PLMN

Requirement:

The NF Service producer shall verify the access token as follows:

- a) The NF Service producer ensures the integrity of the access token by verifying the signature using NRF's public key or checking the Medium Access Control (MAC) value using the shared secret. If integrity check is successful, the NF Service producer shall verify the claims in the access token as follows:
- b) It checks that the audience claim in the access token matches its own identity or the type of NF service producer. If a list of NSSAIs or list of NSI IDs is present, the NF service producer shall check that it serves the corresponding slice(s).
- c) If an NF Set ID is present, the NF Service Producer shall check the NF Set ID in the claim matches its own NF Set ID.
- d) If the access token contains "additional scope" information (i.e. allowed resources and allowed actions (service operations) on the resources), it checks that the additional scope matches the requested service operation.
- e) If scope is present, it checks that the scope matches the requested service operation.
- f) It checks that the access token has not expired by verifying the expiration time in the access token against the current data/time.

If the verification is successful, the NF Service producer shall execute the requested service and respond back to the NF Service consumer. Otherwise, it shall reply based on the Oauth 2.0 error response defined in RFC 6749. The NF service consumer may store the received token(s). Stored tokens may be re-used for accessing service(s) from producer NF type listed in claims (scope, audience) during their validity time.

[Ref [3]: TSDSI STD T1.3GPP 33.117 17.2.0 V1.2.0 Section 4.2.2.2.3.1]

[Ref [12]: RFC 6749 - The OAuth 2.0 Authorization Framework]

2.12.6 Authorization token verification failure handling different PLMNs

Requirement:

The NF service producer shall check that the home PLMN ID of audience claim in the access token matches its own PLMN identity. NF service producer shall not grant service access if the verification of authorization token from a NF service consumer in a different PLMN fails.

[Ref [3]: TSDSI STD T1.3GPP 33.117 17.2.0 V1.2.0 Section 4.2.2.2.3.2]

2.12.7 Protection against JSON injection attacks

Requirement:

NF Service Consumers communicate using JSON on the service-based interfaces with NSACF. NSACF shall never use the eval function to evaluate JSON data to prevent client-side JSON injections. NSACF shall sanitize all data before serializing it to JSON, to prevent server-side JSON injections.

[Ref [16]: ENISA THREAT LANDSCAPE FOR 5G NETWORKS, December 2020]

Section 2.13: Other Security requirements

2.13.1 Remote Diagnostic Procedure – Verification

Requirement:

If the NSACF is providing Remote access for troubleshooting purposes/alarm maintenance then it shall be allowed only for authorized users, other than the root user.

All activities performed by the remote user are to be logged with the following parameters:

- a) User id
- b) Time stamp
- c) Interface type
- d) Event type
- e) Command/activity performed
- f) Result type (e.g., SUCCESS, FAILURE).
- g) IP Address of remote machine

[Ref[32]: GSMA 133: GSM Association Non-confidential Official Document NG.133 - Cloud Infrastructure Reference Architecture managed by OpenStack, section:2.2.7.7]

2.13.2 No System Password Recovery

Requirement:

No provision shall exist for NSACF System / Root password recovery.

2.13.3 Secure System Software Revocation

Requirement:

Once the NSACF software image is legally updated/upgraded with New Software Image, it shall normally not be possible to roll back to a previous software image. In case roll back is essential, it shall be done only by the administrator with appropriate non-repudiation controls.

NSACF shall support a well-established control mechanism for rolling back to previous software image.

2.13.4 Software Integrity Check - Installation

Requirement:

NSACF shall validate the software package integrity before the installation stage strictly using the Secure cryptographic controls prescribed in Table 1 of the latest document "ITSAR for Cryptographic Controls" only.

Tampered software shall not be executed or installed if integrity check fails.

[Ref [3]: TSDSI STD T1.3GPP 33.117 17.2.0 V1.2.0 Section 4.2.3.3.5]

2.13.5 Software Integrity Check - Boot

Requirement:

The NSACF shall verify the integrity of a software component by comparing the result of a measurement of the component, typically a standard cryptographic hash generated strictly

using the Secure cryptographic controls prescribed in Table 1 of the latest document “ITSAR for Cryptographic Controls” to the expected reference value.

Note: This may not be applicable for GVNP Type 1 and Type 2.

2.13.6 Unused Physical and Logical Interfaces Disabling

Requirement:

NSACF shall support the mechanism to verify both the physical and logical interfaces exist in the product.

Physical and logical accessible interfaces (except console interface) which are not under use shall be disabled so that they remain inactive even in the event of reboot.

Note: This may not be applicable for GVNP Type 1 and Type 2.

2.13.7 Predefined accounts shall be deleted or disabled

Requirement:

Predefined or default user accounts (other than Admin/Root) in NSACF shall be deleted or disabled.

[Ref [3]: TSDSI STD T1.3GPP 33.117 17.2.0 V1.2.0 Section 4.2.3.4.2.2]

2.13.8 Correct handling of client credentials assertion validation failure

Requirement:

The verification of the Client credentials assertion shall be performed by the receiving node, i.e. NRF or NF Service Producer in the following way:

- a) It validates the signature of the JSON Web Signature (JWS) as described in RFC 7515.
- b) It validates the timestamp (iat) and/or the expiration time (exp) as specified in RFC 7519.
 - i) If the receiving node is the NF Service Producer, the NF service Producer validates the expiration time and it may validate the timestamp.
- c) It checks that the audience claim in the client credentials assertion matches its own type.

It verifies that the NF instance ID in the client credentials assertion matches the NF instance ID in the public key certificate used for signing the assertion.

[Ref [3]: TSDSI STD T1.3GPP 33.117 17.2.0 V1.2.0 Section 4.2.2.2.4.1]

[Ref [13]: RFC 7515 - JSON Web Signature (JWS)]

[Ref [14]: RFC 7519 - JSON Web Token (JWT)]

Note: Not applicable to Release 16 implementation

2.13.9 Isolation of Compromised Element

Requirement:

In case of any compromise of NSACF, it shall be possible to isolate the NSACF at network and/or compute/storage level. Such provisions shall be documented.

[Ref [19]: ENISA SECURITY IN 5G SPECIFICATIONS, Controls in 3GPP Security Specifications (5G SA) FEBRUARY 2021 Section 4.1.3]

Chapter 3 – Specific Security Requirements

Section 3.1 NSACF Database related Requirements

3.1.1 Removal of default accounts in database

Requirement:

All default or predefined accounts (e.g., test@localhost) that are not required for the operation of the NSACF database shall be deleted permanently.

[Ref [3]: TSDSI STD T1.3GPP 33.117 17.2.0 V1.2.0 Section 4.2.3.4.2.2]

3.1.2 Renaming Of root/admin account in the database

Requirement:

The administrative (superuser) account on a NSACF database (used for database administration) shall not have a simple/well-known name such as 'root@localhost' in order to avoid exposing a highly privileged account with an easy to guess name.

[Ref [29]: ITSAR for HSS V1.0.0 section 3.2]

3.1.3 Removal of default database

Requirement:

Default or test databases that are not required for normal operation of NSACF shall be deleted.

[Ref [3]: TSDSI STD T1.3GPP 33.117 17.2.0 V1.2.0 Section 4.3.2.3]

3.1.4 Password management for the database

Requirement:

NSACF database shall only accept passwords that comply with the following complexity criteria:

- a) Absolute minimum length of 8 characters (shorter lengths shall be rejected by the network product). It shall not be possible setting this absolute minimum length to a lower value by configuration.
- b) Comprising at least three of the following categories:
 - i) at least 1 uppercase character (A-Z)
 - ii) at least 1 lowercase character (a-z)
 - iii) at least 1 digit (0-9)
 - iv) at least 1 special character (e.g., @;!\$.)

The default minimum length of password in the NSACF database shall be 10 characters. The minimum length of characters in the passwords shall be configurable by the operator.

If a central system is used for user authentication, password policy is performed on the central system and additional assurance shall be provided that the central system enforces the same password complexity rules as laid down for the local system in this subclause. If a central system is not used for user authentication, the assurance on password complexity rules shall be performed on the NSACF Database.

When a user is changing a password or entering a new password, the system checks and ensures that it meets the password requirements.

- c) Following password expiration and reuse policy shall be used:
 - i) Password Expiration: Change immediately based on events, with an OEM/operator defined expiration “backstop”.
 - ii) Password reuse restrictions: To prevent old passwords from being chosen again, reuse of at least last 5 passwords shall be denied.
- d) At least two-factor authentication shall be used for NSACF database access.

[Ref [3]: TSDSI STD T1.3GPP 33.117 17.2.0 V1.2.0 Section 4.2.3.4.3.1]

[Ref [25]: CIS_Benchmarks_Password_Policy_Guide_v21.12]

3.1.5 Protection of the NSACF database

Requirement:

NSACF database shall be protected as per TSDSI STD T1.33.117-17.1.0 V1.1.0. Section 4.2.3.2.3. and wherever encryption/hashing is mandated it shall be as per cryptographic controls prescribed in Table 1 of the latest document “ITSAR for Cryptographic Controls”.

[Ref [3]: TSDSI STD T1.33.117-17.1.0 V1.1.0. Section 4.2.3.2.3]

3.1.6 Database specific logging

Requirement:

- a) Security events related to following database events shall be logged together with a unique reference (e.g., database name, user ID accessing the database) and the exact time the incident occurred.
 - i) Database Management Server Login (success or error) events
 - ii) Attempted/executed database statements/queries
- b) Information available in the logs about authentication attributes shall be masked.
- c) NSACF shall support real-time forwarding of security event logging data to an external system. Secure transport protocols shall be used in accordance with section 2.1.2 of the current document.
- d) Log functions should support secure uploading of log files to a central location or to an external system for the NSACF database that is logging.

[Ref [3]: TSDSI STD T1.33.117-17.1.0 V1.1.0. Section 4.2.3.6]

3.1.7 User privileges on the database

Requirement:

All NSACF database server users shall perform only the operations that are permitted to them (as per the privileges assigned to them). Principle of 'least privilege' shall be used.

[Ref [3]: TSDSI STD T1.3GPP 33.117 17.2.0 V1.2.0 Section 4.2.3.4.6.1 and 4.2.3.4.6.2]

3.1.8 Unique Identity

Requirement:

All database user accounts shall be uniquely identified (for e.g., username, hostname) by the NSACF database.

[Ref [3]: TSDSI STD T1.3GPP 33.117 17.2.0 V1.2.0 Section 4.2.3.4.1.2 and Section 4.2.4.2.2]

3.1.9 Protection from attacks

Requirement:

- a) NSACF database shall be protected from database injection attacks.
- b) Port used by the database service shall not be accessed by unauthorized entities. NSACF database shall use a different port other than the default port for its connections.
- c) Database shall recover securely from corruption, loss, damage.
- d) Database shall support security mechanisms to protect from DDoS attacks.
- e) Database systems shall provide security measures to deal with overload situations which may occur as a result of a denial of service attack or during periods of increased traffic. In particular, partial or complete impairment of system availability shall be avoided.
- f) Potential protective measures shall include, but is not limited to the following:
 - i) Use stored procedures instead of implementing Direct queries
 - ii) The number of queries an account can issue per hour shall be restricted.
 - iii) The number of updates an account can issue per hour shall be restricted.
 - iv) The number of times an account can connect to the server per hour shall be restricted.
 - v) The number of simultaneous connections to the server by an account (global max_user_connections value is 10) shall be restricted.
 - vi) Validating and encoding all user inputs

[Ref [21]: <https://owasp.org/www-community/attacks>]

3.1.10 NSACF Database Integrity

Requirement:

Systems and mechanisms shall be in place to ensure integrity of NSACF database. The documentation on specific methods or approaches used to address the integrity of NSACF database shall be provided.

3.1.11 NSACF Database Availability

Requirement:

Systems and mechanisms shall be in place to ensure availability of NSACF database. The documentation on specific methods or approaches used to address the availability of NSACF database shall be provided.

3.1.12 Support for 'Data Redaction' and 'Data Masking' feature

Requirement:

NSACF database shall support features of data redaction/log redaction and data masking to prevent exposure of sensitive data.

3.1.13 Terminate session on logout or session termination event

Requirement:

When a user logs out, or when any other session termination event occurs, the NSACF database must delete the user session(s) to minimize the potential for session(s) to be hijacked.

[Ref [27]: NIST SP 800-53 Rev. 5: SC-23 SESSION AUTHENTICITY]

3.1.14 Fail in known secure state

Requirement:

The NSACF database must transition to a known secure state if failure occurs.

The principle of secure failure indicates that components fail in a state that denies rather than grants access. That is, In a known secure state, neither a failure in a system function or mechanism nor any recovery action in response to failure leads to a violation of security policy. The system may provide all or part of the functionality of the original system, or it may completely shut itself down to prevent any further violation of security policies.

[Ref [27]: NIST SP 800-53 Rev. 5: SC-24 FAIL IN KNOWN STATE and SA-8 SECURITY AND PRIVACY ENGINEERING PRINCIPLES- (23), (24)]

3.1.15 Disable server-side scripting if not needed

Requirement:

The NSACF database shall ensure that server-side scripting is disabled if not needed.

[Ref [30]: Security Standard –Database Management Systems (SS-005) section 11.2.3]

3.1.16 Restrict access using IP filtering

Requirement:

The NSACF database shall restrict access using IP filtering.

[Ref [30]: Security Standard –Database Management Systems (SS-005) section 11.2.11]

3.1.17 Database backup

Requirement:

The mechanisms for data base backups, integrity, consistency and availability shall be supported.

[Ref [20]: OWASP Database_Security_Cheat_Sheet]

[Ref [30]: Security Standard –Database Management Systems (SS-005) section 11.5.1]

Section 3.2. Network slice Admission Control Service

3.2.1 NSACF supervision/reporting data protection

Requirement:

During the operation phase of management aspects of a Network Slice Instance, supervision and performance reporting (e.g. for KPI monitoring) from NSACF are included. NSI modification can be triggered by the result of supervision/reporting of NSACF, so protecting the integrity of the result of the supervision/reporting data from NSACF is important. A tampered result may cause an unnecessary or improper NSI modification action such as creation or modification of NSI constituents. Thus,

- The supervision and reporting data shall be integrity protected.
- The supervision and reporting data shall be confidentiality protected

[Ref [32]: TR 33.811 v15.0.0 section 4.2]

[Ref [27]: NIST SP 800-53 Rev. 5: SC-8 Transmission confidentiality and integrity]

3.2.2 Protection against potential leakage of sensitive information

Requirement:

NSACF shall protect against potential leakage of slicing-related sensitive information of both operator and subscriber while sending notification or report to a consumer NF (e.g. AF). Encryption, redaction, masking, cryptographic protection of message externals like message headers and routing information are some potential ways to prevent data leakage.

[Ref [27]: NIST SP 800-53 Rev. 5: SC-8 Transmission confidentiality and integrity]

Definitions

1. **5G Access Network:** An access network comprising a NG-RAN and/or non-3GPP AN connecting to a 5G Core Network. [1]
2. **5G Core Network:** The core network specified in the present document. It connects to a 5G Access Network. [1]
3. **5G System:** 3GPP system consisting of 5G Access Network (AN), 5G Core Network and UE. [1]
4. **DDoS:** DDoS is a distributed denial-of-service attack that renders the victim un-usable by the external environment.
5. **Generic Network Product:** Generic Network Product (GNP) model as defined in Section 4.1 and 4.3 of TSDSI RPT T1.3GPP 33.926-16.4.0 V1.0.0. [24]
6. **Generic virtualized network product model (GVNP) Type 1:** GVNP Model as defined in Section 5.2.3 of TSDSI RPT T1.3GPP 33.818-17.1.0 V1.0.0. [23]
7. **Generic virtualized network product model (GVNP) Type 2:** GVNP Model as defined in Section 5.2.3 of TSDSI RPT T1.3GPP 33.818-17.1.0 V1.0.0. [23]
8. **Generic virtualized network product model (GVNP) Type 3:** GVNP Model as defined in Section 5.2.3 of TSDSI RPT T1.3GPP 33.818-17.1.0 V1.0.0. [23]
9. **Home Environment:** responsible for overall provision and control of the Personal Service Environment of its subscribers. [10]
10. **Machine Accounts:** These will be used for authentication and authorization from system to system or between applications on a system and cannot be assigned to a single person or a group of persons. [3]
11. **Masking:** The process of systematically removing a field or replacing it with a value in a way that does not preserve the analytic utility of the value. [34]
12. **Medium Access Control:** A sub-layer of radio interface layer 2 providing unacknowledged data transfer service on logical channels and access to transport channels.
13. **Mobile Equipment (ME):** The Mobile Equipment is functionally divided into several entities, i.e. one or more Mobile Terminations (MT) and one or more Terminal Equipments (TE). [3]
14. **Network Function:** A 3GPP adopted or 3GPP defined processing function in a network, which has defined functional behaviour and 3GPP defined interfaces. NOTE 1: A network function can be implemented either as a network element on a dedicated hardware, as a software instance running on a dedicated hardware, or as a virtualized function instantiated on an appropriate platform, e.g., on a cloud infrastructure. [1]
15. **NF service:** a functionality exposed by a NF through a service-based interface and consumed by other authorized NFs. [1]

16. **NF Set ID:** A NF Set Identifier (NF Set ID) is a globally unique identifier of a set of equivalent and interchangeable Control Plane NFs from a given network that provide distribution, redundancy and scalability (see clause 5.21.3 of TS 23.501 [1]).
17. **NSI:** Network Slice Instance-A set of Network Function instances and the required resources (e.g. compute, storage and networking resources) which form a deployed Network Slice. [1]
18. **NSS:** Network slice Subnet-A representation of the management aspects of a set of Managed Functions and the required resources (e.g. compute, storage and networking resources) -(GSMA 116) Network slices are generally composed of network slice subnets (e.g. *RAN network slice subnet, Core network slice subnet and Transport network slice subnet*)-(3gpp) [1] [33]
19. **NSSAA:** Network Slice-Specific Authentication and Authorization-A serving PLMN or SNPN shall perform Network Slice-Specific Authentication and Authorization for the S-NSSAIs of the HPLMN or SNPN which are subject to it based on subscription information. The UE shall indicate in the Registration Request message whether it supports NSSAA feature. If the UE does not support NSSAA feature, AMF will not trigger the procedure. [1]
20. **NSSAI:** Network Slice Selection Assistance Information-*The NSSAI is a collection of S-NSSAIs.* An NSSAI may be a Configured NSSAI, a Requested NSSAI or an Allowed NSSAI. *There can be at most eight S-NSSAIs in Allowed and Requested NSSAIs* sent in signalling messages between the UE and the Network. [1]
21. **NSSF:** Network Slice Selection Function-The selection of the set of Network Slice instances for a UE is triggered by the first contacted AMF in a Registration procedure normally by interacting with the NSSF. [1]
22. **NSSI:** Network slice subnet instance-An instance of Network Slice Subnet representing the management aspects of a set of Managed Function instances and the used resources (e.g. compute, storage and networking resources). [1]
23. **NSSP:** Network Slice Selection Policy-This is used by the UE to associate the matching application with S- NSSAI. ^[1]PCF provisions *URSP rules* to the UE. UE uses *URSP rules (which contains NSSP)* for associating the matching application with S-NSSAI. [1]
24. **NSSRG:** Network Slice Simultaneous Registration Group-The UE Subscription Information may contain restrictions to the simultaneous registration of network slices. This is provided to the serving AMF as part of the UE subscription, in the form of Network Slice Simultaneous Registration Group (NSSRG) information. [1]
25. **Personal data:** Any information relating to an identified or identifiable natural person ('data subject'). [3]
26. **Personal Service Environment:** contains personalized information defining how subscribed services are provided and presented towards the user. Each subscriber of the Home Environment has her own Personal Service Environment. The Personal Service Environment is defined in terms of one or more User Profiles. [10]

27. **Protocol:** A formal set of procedures that are adopted to ensure communication between two or more functions within the same layer of a hierarchy of functions (source: ITU-T I.112). [10]
28. **Protocol data unit (PDU):** In the reference model for OSI, a unit of data specified in an (N)-protocol layer and consisting of (N)-protocol control information and possibly (N)-user data (source: ITU-T X.200 / ISO-IEC 7498-1). [3]
29. **Public Land Mobile Network (PLMN):** A telecommunications network providing mobile cellular services. [3]
30. **Quality of Service (QoS):** The collective effect of service performances which determine the degree of satisfaction of a user of a service. It is characterized by the combined aspects of performance factors applicable to all services, such as;
- service operability performance;
 - service accessibility performance;
 - service retainability performance;
 - service integrity performance; and
 - other factors specific to each service. [3]
31. **Redaction:** The removal of information from a document or dataset for legal or security purposes. [34]
32. **Secure state:** A system state is defined to be "secure" if the only permitted access modes of subjects to objects are in accordance with an organizational security policy.
33. **Sensitive data:** data that may be used for authentication or may help to identify the user, such as user names, passwords, PINs, cryptographic keys, IMSIs, IMEIs, MSISDNs, or IP addresses of the UE, as well as files of a system that are needed for the functionality such as firmware images, patches, drivers or kernel modules. [3]
34. **Serving Network:** The serving network provides the user with access to the services of home environment. [10]
35. **Universal Subscriber Identity Module (USIM):** An application residing on the UICC used for accessing services provided by mobile networks, which the application is able to register on with the appropriate security. [3]
36. **User Equipment (UE):** Allows a user access to network services. For the purpose of 3GPP specifications the interface between the UE and the network is the radio interface. A User Equipment can be subdivided into a number of domains, the domains being separated by reference points. Currently the User Equipment is subdivided into the UICC domain and the ME Domain. The ME Domain can further be subdivided into one or more Mobile Termination (MT) and Terminal Equipment (TE) components showing the connectivity between multiple functional groups. [3]

Acronyms

3GPP	-	Third Generation Partnership Project
4G	-	Fourth Generation
5G	-	Fifth Generation
5GC	-	5G Core
5GS	-	5G System
AAA	-	Authentication, Authorization and Accounting
AF	-	Application Function
AMF	-	Access and Mobility Management Function
AN	-	Access Network
API	-	Application Programming Interfaces
ARP	-	Address Resolution Protocol
AS	-	Access Stratum
AUSF	-	Authentication Server Function
BOOTP	-	Bootstrap Protocol
CAPTCHA	-	Completely Automated Public Turing test to tell Computers and Humans Apart
CD	-	Compact Disk
CDP	-	Cisco Discovery Protocol
CGI	-	Common Gateway Interface
CIS	-	Center for Internet Security
CISA	-	Cybersecurity and Infrastructure Security Agency
CLI	-	Command-Line Interface
CN	-	Core Network
CP	-	Control Plane
CPU	-	Central Processing Unit
CWE	-	Common Weakness Enumeration
DDoS	-	Distributed Denial of Service
DN	-	Data Network
DNS	-	Domain Name System
DoT	-	Department of Telecommunications
DVD	-	Digital Versatile Disk
E-UTRA	-	Evolved Universal Terrestrial Radio Access
eMBB	-	Enhanced Mobile Broadband
ENISA	-	European Union Agency for Cybersecurity
EPC	-	Evolved Packet Core
ETSI	-	European Telecommunications Standards Institute

FIPS	-	Federal Information Processing Standards
FTP	-	File Transfer Protocol
gNB	-	Next Generation Node B
GUI	-	Graphical User Interface
GVNP	-	Generalized Virtual Network Product
HE	-	Home Environment
HTTP	-	Hypertext Transfer Protocol
HTTPS	-	Hyper Text Transfer Protocol Secure
ICMP	-	Internet Control Message Protocol
ICMPv4	-	ICMP version 4
ICMPv6	-	ICMP version 6
IE	-	Information Element
IEEE	-	Institute of Electrical and Electronics Engineers
IETF	-	Internet Engineering Task Force
IMT	-	International Mobile Telecommunications
IP	-	Internet Protocol
IPSec	-	Internet Protocol Security
IPv4	-	IP version 4
IPv6	-	IP version 6
ISO	-	International Organization for Standardization
ISP	-	Internet service provider
IT	-	Information Technology
ITSAR	-	Indian Telecommunication Security Assurance Requirements
ITU	-	International Telecommunication Union
JSON	-	JavaScript Object Notation
JWS	-	JSON Web Signature
JWT	-	JSON Web Token
LLDP	-	Link Layer Discovery Protocol
LTE	-	Long Term Evolution
MAC	-	Medium Access Control
ME	-	Mobile Equipment
mMTC	-	Massive Machine Type Communication
MOP	-	Maintenance Operations Protocol
MTD	-	Malware Test Document
NAS	-	Non Access Stratum
NCCS	-	National Centre For Communication Security
NEF	-	Network Exposure Function
NF	-	Network Function
NFV	-	Network Function Virtualization
NIST	-	National Institute of Standards and Technology

NR	-	New Radio
NRF	-	Network Repository Function
NSA	-	National Security Agency
NSA	-	Non-Standalone
NSI	-	Network Slice Instance
NSS	-	Network slice Subnet
NSSAA	-	Network Slice-Specific Authentication and Authorization
NSSAI	-	Network Slice Selection Assistance Information
NSSF	-	Network Slice Selection Function
NSSI	-	Network slice subnet instance
NSSP	-	Network Slice Selection Policy
NSSRG	-	Network Slice Simultaneous Registration Group
NTP	-	Network Time Protocol
NTS	-	Network Time Security
OAM	-	Operations, Administration and Management
OEM	-	Original Equipment Manufacturer
OS	-	Operating System
OSI	-	Open Systems Interconnection
OWASP	-	Open Worldwide Application Security Project
P2P	-	Peer
PAD	-	Packet Assembler/Disassembler
PCF	-	Policy Control Function
PII	-	Personal Identifiable Information
PLMN	-	Public Land Mobile Network
PTP	-	Precision Time Protocol
QoS	-	Quality of Service
RAM	-	Random Access Memory
RAN	-	Radio Access Network
RAT	-	Radio Access Technology
RBAC	-	Role Based Access Control
RCP	-	Rate Control Protocol
RDP	-	Remote Desktop Protocol
REST	-	Representational State Transfer
RFC	-	Request For Comment
RPF	-	Reverse Path Filter
RSH	-	Remote Shell Protocol
RTP	-	Real Time Protocol
SA	-	Standalone
SBA	-	Service Based Architecture
SBI	-	Service Based Interface

SDN	-	Software Defined Networking
SFTP	-	Secure File Transfer Protocol
SMF	-	Session Management Function
SMS	-	Short Message Service
SN	-	Serving Network
SNMP	-	Simple Network Management Protocol
SSH	-	Secure Shell
SSI	-	Server Side Includes
SSL	-	Secure Sockets Layer
STD	-	Software Test Document
TCP	-	Transmission Control Protocol
TFTP	-	Trivial File Transfer Protocol
TLS	-	Transport Layer Security
TSDSI	-	Telecommunications Standards Development Society
TSTL	-	Telecom Security Testing Laboratory
UDM	-	Unified Data Management
UDP	-	User Datagram Protocol
UDR	-	Unified Data Repository
NSACF	-	Network Slice Admission Control Function
UE	-	User Equipment
UID	-	User ID
UP	-	User Plane
UPF	-	User Plane Function
URL	-	Uniform Resource Locator
uRLLC	-	Ultra Reliable and Low Latency Communications
USB	-	Universal Serial Bus
USIM	-	Universal Subscriber Identity Module
VPN	-	Virtual Private Network
WebDAV	-	Web based Distributed Authoring and Versioning
WLAN	-	Wireless Local Area Network

List of Submissions

List of undertaking to be furnished by the OEM for NSACF Security testing

1. Source Code Security Assurance (against test case 2.3.3)
2. Known Malware and backdoor Check (against test case 2.3.4)
3. No unused software (against test case 2.3.5)
4. No unsupported components (against test case 2.4.2)
5. Avoidance of Unspecified mode of Access (against test case 2.4.3)
6. Cryptographic Module Security Assurance (against test case 2.6.2)
7. Cryptographic Algorithms implementation Security Assurance (against test case 2.6.3)

Annexure- IV

References

1. TSDSI STD T1.3GPP 23.501 17.7.0 V1.3.0 “System architecture for the 5G System (5GS)”
2. TSDSI STD T1.3GPP 33.501-17.7.0 V1.1.0 “System architecture and procedures for 5G System”
3. TSDSI STD T1.3GPP 33.117 17.2.0 V1.2.0 “Catalogue of general security assurance requirements”
4. https://cwe.mitre.org/top25/archive/2022/2022_cwe_top25.html
5. <https://owasp.org/www-project-top-ten/>
6. <https://owasp.org/www-project-api-security/>
7. RFC 8915 - Network Time Security for the Network Time Protocol (NTP)
8. <https://nvlpubs.nist.gov/nistpubs/FIPS/NIST.FIPS.140-2.pdf>
9. <https://nvd.nist.gov/vuln-metrics/cvss>
10. 3GPP TR 21.905 V17.1.0 (2021-12) “Vocabulary for 3GPP Specifications
11. RFC 3871 - Operational Security Requirements for Large Internet Service Provider (ISP) IP Network Infrastructure
12. RFC 6749 - The OAuth 2.0 Authorization Framework
13. RFC 7515 - JSON Web Signature (JWS)
14. RFC 7519 - JSON Web Token (JWT)
15. TSDSI STD T1.3GPP 33.127 17.7.0 V1.3.0 “Lawful Interception (LI) architecture and functions”
16. ENISA THREAT LANDSCAPE FOR 5G NETWORKS, Updated threat assessment for the fifth generation of mobile telecommunications networks (5G), December 2020
17. ENISA Recommendation “Standardization in support of the cybersecurity certification”, Dec 2019
18. “Security Guidance for 5G Cloud Infrastructure Part III: Data Protection” by NSA & CISA
https://www.cisa.gov/sites/default/files/publications/Security_Guidance_For_5G_Cloud_Infrastructures_Part_III_508_Compliant.pdf
19. ENISA SECURITY IN 5G SPECIFICATIONS, Controls in 3GPP Security Specifications (5G SA) FEBRUARY 2021 Section 4.1.3
<https://www.enisa.europa.eu/publications/security-in-5g-specifications>

20. [https://cheatsheetseries.owasp.org/cheatsheets/Database Security Cheat Sheet.html](https://cheatsheetseries.owasp.org/cheatsheets/Database_Security_Cheat_Sheet.html)
21. [https://owasp.org/www-community/attacks/SQL Injection#](https://owasp.org/www-community/attacks/SQL_Injection#)
22. TSDSI STD T1.3GPP 23.632-17.3.0 V1.2.0 “User data interworking, coexistence and migration”
23. TSDSI RPT T1.3GPP 33.818-17.1.0 V1.0.0 “Security Assurance Methodology (SECAM) and Security Assurance Specification (SCAS) for 3GPP virtualized network products”
24. TSDSI RPT T1.3GPP 33.926-16.4.0 V1.0.0 “Security Assurance Specification (SCAS) threats and critical assets in 3GPP network product classes”
25. CIS_Benchmarks_Password_Policy_Guide_v21.12
26. MongoDB_Security_Architecture_WP.pdf
27. <https://nvlpubs.nist.gov/nistpubs/SpecialPublications/NIST.SP.800-53r5.pdf>
28. GSMA NG 133 Cloud Infrastructure Reference Architecture
29. ITSAR for HSS V1.0.0
30. https://assets.publishing.service.gov.uk/government/uploads/system/uploads/attachment_data/file/1175185/dwp-ss005-security-standard-database-management-systems.pdf
31. TSDSI STD T1.3GPP 29.536-17.2.0 V1.2.0
32. TR 33.811 v15.0.0
33. <https://www.gsma.com/newsroom/wp-content/uploads/NG.116-v8.0-1.pdf>
34. <https://csrc.nist.gov/glossary>
35. 3GPP TS 29.501 V17.2.0 Principles and Guidelines for Services Definition Stage 3
36. GSMA 133: GSM Association Non-confidential Official Document NG.133 - Cloud Infrastructure Reference Architecture managed by OpenStack